



2007 DTAS Keynote Presentation

Damage Tolerance

Facts and Fiction

Dr. Ulf G. Goranson, FRAeS

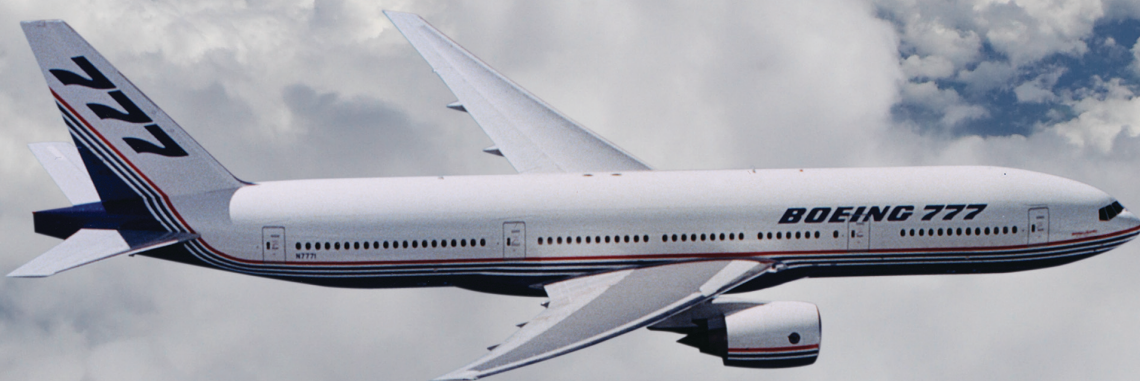

Damage Tolerance Facts and Fiction

Ulf G. Goranson

Boeing Commercial Airplane Company
Seattle, Washington, U.S.A.

Keynote Presentation

International Conference on Damage Tolerance of Aircraft Structures

25th September, 2007

Delft Technical University
Delft, The Netherlands

ISBN: 978-90-9022230-1

TRIBUTE TO MY FRIEND - JAAP SCHIJVE

I joined Boeing and the US Supersonic Transport Program in 1967. I was fortunate to soon become involved in the review and preparation of US National Review inputs to the International Committee of Aeronautical Fatigue (ICAF). This afforded me opportunities to read and learn from the giants in the area of fatigue and fracture, especially Professor Jaap Schijve. I never imagined in those days that in future ICAF meetings, that I and my wife Inger would be privileged to meet with Jaap and Janine and visit their home in Pijnacker in The Netherlands and to call them our dear friends.

As my career progressed at Boeing, I was asked to co-author papers with chief engineers. While a sometimes frustrating occupation, I had the opportunity to read many masterpieces authored by Jaap. For a paper entitled "Spectrum Loading in Relation to Aircraft Design", presented at the 8th ICAF Symposium in Lausanne Switzerland in 1975, I had a chance to work through some superb reports written by Jaap:

- Cumulative Damage Problems in Aircraft Structures and Materials, ICAF – Stockholm, 1969. (NLR MP 69005 – Amsterdam 1969)
- The Accumulation of Fatigue Damage in Aircraft Structures and Materials. AGARD Symposium on Random Fatigue 1972 (AGARD CP 118)

When Boeing designed and built the new models 757 and 767 in the late 1970's, the formulation and acceptance of new principles for full scale fatigue test spectra became a monumental personal challenge. I was fortunate to have opportunities to calibrate our approaches with Jaap in those difficult days. In the end, the executive management team approved the 5x5 spectra approach, an evolution from the Transport Wing Spectrum Test (TWIST) spectra developed by Jaap. The approach with 5 flight types and 5 spectrum load levels made it possible to realistically represent flight by flight ground and air loads with sufficient precision and in challenging time frames. Substantial test verification of small test specimens and large panels made it possible to meet regulatory requirements on analysis tool verification for spectrum crack growth evaluations, a major element of realistic inspection programs.

I finished my Boeing tenure as Chief Engineer, responsible for Structures Technology Standards and Structures Laboratories. I was fortunate to direct the full scale fatigue test and ancillary damage tolerance testing of the Boeing 777 airplane. The now mature 5x5 spectrum test technology built on a foundation set by Jaap, again made it possible to reliably verify the structural integrity of this new generation of jet transports.

With the ever present urge to accelerate fatigue tests, it was amusing to relate to the wisdom of Jaap coaching younger engineers. The basic TWIST spectra were no doubt time consuming and MiniTWIST versions emerged. These spectra comprised less load points and cycled faster, but in the end required more repetitions to match the results of TWIST, in other words, both ending up with similar test flow times.

I had the opportunity to participate in the celebration of Jaap's 65th birthday celebration and the Conference on Fatigue of Aircraft Materials at the Delft University of Technology in 1992 with a presentation on "Elements of Structural Integrity Assurance". I am truly honoured to be part of this International Conference on Damage Tolerance of Aircraft Structures (DTAS) in Delft, September 2007 to celebrate the 80th birthday of Jaap.

Dr. Ulf G. Goranson
Boeing Senior Technical Fellow

DAMAGE TOLERANCE — FACTS AND FICTION

Ulf G. Goranson

ABSTRACT

Design, analysis and verification of damage tolerant structures embraces both structural characterization and damage detection assessments. Methods to determine fatigue performance, crack growth and residual strength of complex details have improved significantly since the introduction of commercial jet transports. Less technology development has occurred on integrating this capability in development of structural inspection program recommendations reflecting the value of normal operator maintenance activities. Damage detection considerations required to achieve a flexible maintenance program without compromising structural safety are addressed in this review.

INTRODUCTION

Design of safe and competitive jet transport structures involves a host of significant considerations. This review is focused on continued airworthiness challenges in terms of evolution of design and verification requirements, analysis methods and examples of lessons learned.

Design of structures is fundamentally a guided interactive process aimed at achieving a practical balance between state-of-the-art structural capability and the intended usage requirements. These capabilities and requirements are typically evaluated against each other through a disciplined design process comprising regulations, methods and analysis, data bases, validation tests, etc. Static design of structures has evolved since the infancy of aviation towards widely accepted analysis methods and allowables design and verification procedures which reflect cumulative service experience. Development of equivalent disciplined design and analysis methods for damage tolerance has suffered due to the absence of widely accepted and practical evaluation procedures. Floating industry procedures tend to prevent timely and systematic improvements through feedback of experience into standardized procedures for structural evaluations.

Modern airplanes operate in a complex combination of external load sources, environments, human elements and economic requirements. The primary airframe components are designed to specific static and dynamic loading conditions, deformation and functional criteria. Operating service loading criteria for design and verification of durability and damage tolerance are equally important. Fatigue and consequent cracks have been a challenge for the airplane industry since the time of the Wright brothers.

Development of Boeing technology standards over the last twenty years have been focused on a practical balance between simplicity and technical credibility aimed at

providing structures engineers with useful and service/test validated analysis tools. Although much essential knowledge was obtained with moderate reliance on computers, large-scale durability and damage tolerance analyses would not be feasible without computers and associated developments of numerical methods of stress analysis. The challenge of providing visibility of key parameters remains omnipotent to retain true engineering coupled with experience and realism of results.

Design Principles

Static Strength Design. Structural design criteria have evolved since the infancy of aviation to achieve structural strength in the absence of accidental, corrosion and fatigue damage. Design limit loads for maneuvers, gust and ground loading conditions are based on millions of commercial airplane flights. There is very little regulatory guidance given on stressing methods for structures subjected to these loads since such analysis tools have evolved based on cumulative experience to a point where it is exceptional for airframes not to attain design limit/ultimate load levels in full-scale verification tests. Primary airframe components are designed to meet specific static and dynamic loading conditions, deformation and functional criteria. The overall capability of the undamaged primary airplane structure to meet static strength requirements is demonstrated by analysis and supported by test evidence.

Safe-Life Designs. Reliance of safe-life principles for continued airworthiness of early commercial airplanes were to some degree successful. This was primarily due to rapid technology developments rendering airplanes obsolete before serious challenges of the established life limits. Conversion of World War II bombers to airliners caused some airworthiness authority concerns which resulted in limits of operational lives and/or initiated measures for non-destructive testing.

In the 1950s, it became clear that static strength criteria had to be supplemented by estimated replacement times for some critical structural elements such as spar beams on numerous one-spar and two-spar wings. Many such configurations had evolved during the military bomber type developments during World War II.

It became clear that fatigue failures would likely be due to use of high strength aluminum alloys without corresponding increase in fatigue strength. Further compounding the problem was improved stress analysis methods coupled with detailed and full-scale static testing of structural components, which often would eliminate past hidden static strength margins. The knowledge of actual operating conditions also became more extensive which provided more

precise static strength analyses based on rational ultimate design conditions.

Important lessons were learned and fatigue test requirements emerged. Repeated load testing was for instance performed on the Comet I in 1950. These tests were carried out on the same wings used for ultimate static strength tests. The influence of these high loads on cumulative fatigue damage is today self evident but not recognized at the time. It was also recognized through experience that first defects in the fleets could occur at less than a quarter of the test demonstrated life. The attempts to design for a certain life was gradually changed to control fatigue life by limiting major component service lives. The use of imprecise and inaccurate fatigue analyses coupled with inherent material scatter characteristics often resulted in unnecessarily short lives and many sound structures were retired prematurely. Implementing safe-life principles often resulted in political problems for some airplane types in service in different countries. The overall problem with the safe-life principles were indeed that an acceptable commercial airliner safety standard could not be economically achieved.

Today, safe-life design principles are typically limited to ground loaded structures such as high strength landing gear steel components for which substantial fatigue test verification is required.

Fail-Safe Concepts. Most of the inherent problems of the safe-life principles were addressed by adoption of the fail-safe concepts in the late 1950s, spurred by such experiences as the Comet accidents. The primary emphasis at that time was on a multiple structural member concept with established strength requirements for failure of a single structural element or an obvious partial failure. Considerable testing was conducted to verify design concepts. Fail-safe structures achieved safety levels equivalent to prudent safe-life designs more economically, but specific limits on the maximum risk that eventually would be experienced were not explicit.

Experience has shown that the fail-safe design philosophy has generally been effective in allowing sufficient opportunities for timely detection of structural damage. The design envelope criteria were intended to represent more critical conditions than would normally be encountered by partial failures and adjacent structural cracking.

The analysis verification was typically based on static strength evaluations for different structural member failures scenarios. This would often lead to residual strength demonstration by analysis of defined obvious failures rather than showing that all the partial failures with insufficient residual strength were obvious. Failure modes were not always predicted with sufficient accuracy to ensure that structural failures would be obvious and safe. Further, structural failures could progress in unanticipated ways and older airplanes were found with quite unexpected defects.

Fail-safe structures have served commercial jet transports well in terms of credible but imperfect safety records. Accidental damage and corrosion related deteriorations have

been sustained in numerous cases without compromising structural safety. The fail-safe design concept is founded on redundancy which indeed has served well for these types of damage. In terms of fatigue damage, particularly in cases of aging airplanes subjected to damage at multiple sites, structural redundancies are not always efficient based on obvious damage design and inspection considerations. Back-to-back fittings may have excellent structural safety capability in terms of accidental damage and/or corrosion while crack initiation in adjacent, redundant members is likely and similar unless the load paths are totally independent or significantly different. Thus, accepting the existence of the circumstances that necessitated redundancy also means accepting that the redundancy is not very effective in some instances to provide desired structural reliability. Moreover, for the reliability to be as expected, it is apparent that both load paths must have adequate structural fatigue life in the first place.

The continued use of aging jet transports beyond typical lives characterized by technical obsolescence of previous generations of commercial airplanes raised questions about the continued structural airworthiness of airplanes designed and certified to the fail-safe principles. By the 1970s it was clear that airline operators were expected to find cracks that were far from obvious and the safety by inspection became more recognized.

The debate among experts in the industry and airworthiness authorities in the mid 1970s became more focused on the adequacy of inspection programs for timely detection in support of fail-safe principles used during the last two decades. Limited full-scale testing in some cases coupled with lack of teardown inspections made it difficult to know where and when to inspect, which inspection methods to use, and more importantly if there would be sufficient opportunities for damage detection.

Combined industry and airworthiness authority activities in the late 1970s promulgated necessary changes of the regulatory requirements to reflect state-of-the-art developments. In addition to residual strength evaluations, damage growth and inspection requirements with considerations of damage at multiple sites were incorporated in FAR/AC 25.571 (Amendment 45) for new airplanes and in CAA Notice 89 and AC 91-56 for development of supplemental inspections of aging airplanes. We had in a sense reached a point in recognizing that safe-life, fail-safe and damage tolerance principles each have some inadequacies and that indeed a combination of all three philosophies are needed in some cases. The redundancy of the fail-safe structure is desirable to the extent economically feasible to provide structural safety. Widespread fatigue damage and independent local damage inspection thresholds depend on fatigue assessments supported by test evidence. Inspection intervals depend on crack growth, residual strength and damage detection assessments recognizing the value of normal inspection programs for corrosion and accidental damage.

Damage Tolerance Principles. Implementation of the damage tolerance principles in 1978 encouraged application of contemporary engineering methods to determine inspection thresholds and intervals. Most manufacturers included dependent damage at multiple sites in early damage tolerance assessments. Independent damage at multiple sites in areas with many similar structural details subjected to similar stresses have provided additional challenges to maintain continued structural airworthiness as discussed later.

It is prudent to recognize the USAF contributions to damage tolerance implementation. These military requirements differ in details but not in principle. Prior to 1958, military airplane designs were based on static strength requirements. Numerous structural cracking problems occurred since material and structural degradation due to repeated loadings were not properly accounted for. The Aircraft Structural Integrity Program (ASIP), initiated in 1958, was based on a fatigue initiation approach and was moderately successful. This essentially safe-life approach was replaced by the fracture mechanics (fatigue crack growth) approach in 1975 which essentially embraces the damage tolerance concepts but with strong emphasis on the assumption that imperfections are present in an early stage of airplane service. Two qualification approaches are used, slow crack growth and fail-safe. Assumed initial flaws are used in either case to determine inspection thresholds and intervals. The use of crack-arrest (fail-safe) structure is rewarded by relaxed limit load requirements based on damage detection opportunities. The current ASIP philosophy used since 1975 has been extremely effective in ensuring structural safety by reducing hull losses by about 80%. The initial flaw concepts have worked well by providing a calibration and comparison of damage tolerance characteristics between airplane models. Slow crack growth qualification based on the initial flaw concepts are not readily applicable for commercial jet transport structures without comparative crack initiation and damage detection assessments.

Planning for continued structural airworthiness is an evolutionary process blending increased understanding of the parameters affecting durability and damage tolerance with service experience. Structural characteristics required to achieve structural design objectives must be satisfied jointly by:

- **Damage Tolerance:** Ability of structure to sustain anticipated loads in the presence of fatigue, corrosion or accidental damage until such damage is detected through inspections or malfunctions and repaired.
- **Durability:** Ability of the structure to sustain degradation from such sources as fatigue, accidental damage and environmental deterioration to the extent that they can be controlled by economically acceptable maintenance and inspection programs.

Interaction between structural damage tolerance and durability characteristics must be recognized in design, manufacturing and operation of modern jet transports.

Design evolution and maintenance requirements are motivated by both safety and economic concerns. While these aspects are difficult to separate entirely, damage tolerance is primarily governed by minimum certification requirements jointly developed by the regulating agencies, manufacturers, and operators. Durability characteristics of damage tolerant structures mainly influence the economics of in-service operation, maintenance and repair, and are dictated by the requirements of a competitive international market.

The introduction of damage tolerance philosophy has stimulated more emphasis on damage detection reliability, particularly for non-destructive inspection methods. Laboratory developed probability of detection (POD) curves are often relied upon in service environments beyond what is justified by experimental evidence. This is an even more serious problem when these methods are called upon to search an area for unknown defects rather than to confirm the presence of a specified type and location. Cracks missed during inspections are often not properly accounted for in POD data. Visual inspection has been and will continue to be the main source of initial detection of previously unknown damage in most commercial jet transport structures. The lack of interest and resolve in the research community to characterize and quantify visual POD data is indeed perplexing.

Inspectability and accessibility characteristics of the structure must be such that general visual methods of damage detection can be confidently employed for the majority of the structure. Directed inspections involving sophisticated damage detection equipment may be acceptable in areas where inaccessibility dictates infrequent inspections and/or to address known in-service problems until modifications are accomplished. Proper damage detection assessments are particularly important for structures with locally hidden details by accounting for different inspections and access directions during normal maintenance.

Certification of commercial jet transports mandates damage tolerant designs in all instances where it can be used without unreasonable penalty. The technical capability has evolved to relate inspection requirements to damage growth which, in the past, were based on service experience. Primary airframe components are designed to meet specific static and dynamic loading conditions that greatly exceed normal operating loads, Figure 1. As the airplane progresses through its service life, damage may occur and reduce static strength capability (residual strength). Structure is damage tolerant if damage that may occur, can be discovered and repaired before the residual strength falls below the regulatory fail-safe capability. The damage detection period is dependent on structural characteristics as well as maintenance and inspection procedures. Once damage has been detected, strength must be restored to the ultimate design level. Aging airplane structure may be affected by widespread fatigue damage that alters the detection requirements. This is due to

the effect of local damage at multiple sites on residual strength capability.

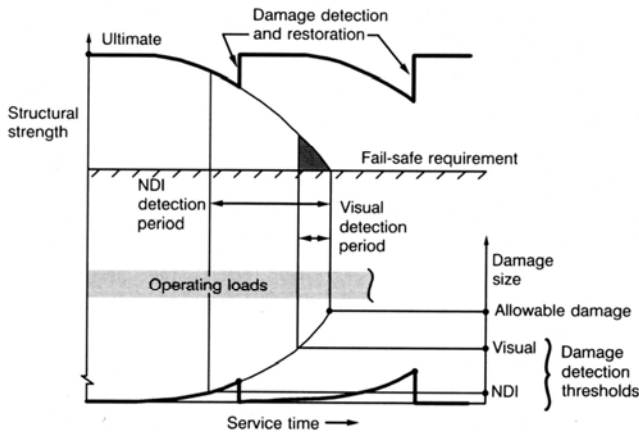

Figure 1. Strength Requirements for Damage Tolerant Structure

Airplane structure can be categorized to determine safety analysis requirements. Any detail, element or assembly, which contributes significantly to carrying flight, ground, pressure or control loads and whose failure could affect the structural integrity necessary for the safety of the airplane is classified as a Principal Structural Element (PSE). The remaining structure is classified as other structure.

| Structural category | | Technique of ensuring safety | Safety analysis requirements | Structural classification examples |
|---|---|--|---|---|
| Other structure | 1 Secondary structure | Design for safe separation or loss of function | • Continued safe flight | Wing spoiler segment (safe separation or safe loss of function) |
| | 2 Damage obvious or malfunction evident | Adequate residual strength with extensive damage obvious during walkaround or indicated by malfunction | • Residual strength | Wing fuel leaks |
| Structurally significant items or Principal structural elements (primary structure) | 3 Damage detection by planned inspection | Inspection program matched to structural characteristics | • Residual strength • Crack growth • Inspection program | All primary structure not included in categories 2 or 4 |
| | 4 Safe life | Conservative fatigue life | • Fatigue | Landing gear structure (conservative fatigue life) |

Figure 2. Structural Classification Examples

Damage tolerance is the preferred principle to achieve structural operating safety based on timely damage detection. Most structure requires an inspection program matched to the structural characteristics for timely damage detection, Category 3, Figure 2. Damage tolerance thus comprises three distinct elements of equal importance for achieving the desired level of safety:

- Residual Strength (Allowable Damage): The maximum damage, including multiple secondary cracks, that the structure can sustain under regulatory fail-safe load conditions which are significantly higher than the maximum loads expected to occur in a typical flight,

- Crack Growth (Damage): The interval of damage progression from lengths below which there is negligible probability of detection to an allowable size determined by residual strength requirements.
- Damage Detection (Inspection Program): A sequence of inspections in a fleet of airplanes with methods and intervals selected to achieve timely damage detection. Structural inspection programs are typically developed by use of rating systems for each of the three major forms of damage, Figure 3.

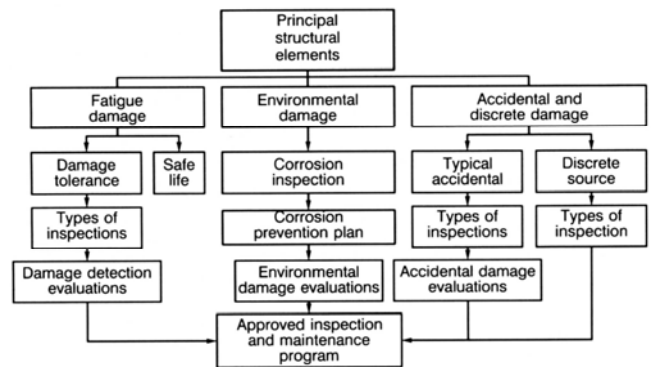

Figure 3. Principal Damage Sources for Maintenance Planning Considerations

To date, damage tolerance and durability evaluations seem to have been useful in restraining designers from using higher stress levels by providing a numerical basis supporting sound engineering judgment. Continued use of first and second generation jet transports offer many challenges to apply damage tolerance principles in a way that will provide safety under ever changing cracking patterns.

ELEMENTS OF DAMAGE TOLERANCE

The key objective for airplane structure designed to the damage tolerance concept has always been to carry regulatory fail-safe loads until detection and repair of any fatigue cracks, corrosion, or accidental damage occurring in service. The fail-safe design approach in the 1950s and 1960s was essentially focused on multi-structural member concepts, with established strength requirements for the failure or obvious partial failure of a single structural element. Considerable testing was conducted to verify these design concepts.

The ability to analyze damaged structure has progressed significantly during the last twenty years through the evolution of fracture mechanics. Assessments now consider residual strength, damage growth, interactive multiple damage sites and quantitative structural maintenance evaluations. Figure 4 shows interaction of damage tolerance elements and the preferred design characteristics. The ability to use the emerging technology advancements has in the past been confined to relatively few specialists in the field of fracture mechanics. Boeing has developed damage tolerance technology standards suitable for use by large teams of structures engineers of varying levels of familiarity with fracture mechanics concepts.

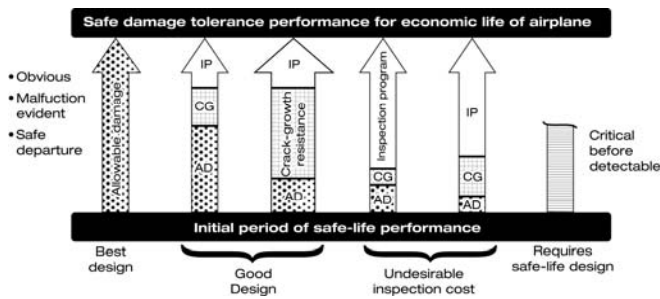

Figure 4. Interaction of Damage Tolerance Elements

Structural maintenance is the cornerstone for ensuring continued airworthiness of damage tolerant structures. The link between complex fracture mechanics analyses and adequate structural inspections is often simplified to selection of inspection intervals as a fraction of the crack growth interval. The key to damage tolerance is damage detection, and therefore more practical detection assessment procedures were developed in the early 1980s. Experience with new model maintenance program developments and supplemental structural inspections of older models have proven that available maintenance resources can be used more efficiently based on damage detection rating systems.

Residual Strength

Technology Standards. The maximum allowable damage that a structure can sustain at a critical fail-safe level is the key to the level of damage growth and inspections needed to ensure damage detection. Malfunction evident or obvious damage structure, described above as Category 2, Figure 2, requires only verification of residual strength capability. Structures described as Category 3 also require crack growth

assessments and damage detection by planned inspection programs.

Monolithic and particularly brittle material structures tend to conform closely to the traditional engineering methods of fracture mechanics. Built-up airplane structures consist of multiple sheet, stiffener, and fastener elements. Interaction between these cracked and uncracked elements causes significant redistribution of stresses. Failures are often precipitated by local exhaustion of plastic strain capability of the most critical elements, and/or net section failures involving a mixture of fracture mechanics and transitional behavior in some elements. Special failure criteria and deflection parameters are necessary to characterize the residual strength properties for damage levels ranging from short secondary cracks in adjacent details to larger primary cracks in details subject to inspection, Figure 5.

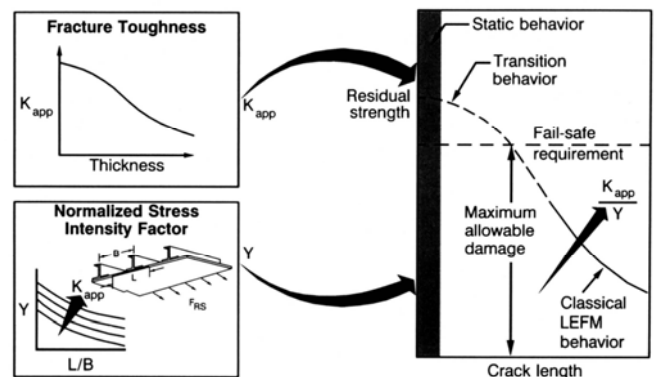

Figure 5 Residual Strength Technology Standards

Fracture toughness properties define the ability of a material to resist rapid fracture in the presence of fatigue cracks or other flaws. Fracture toughness is characterized by plane stress or transitional stress conditions that are complicated by the degree of crack-tip plasticity and associated stable crack extension manifested prior to failure. Consideration of these characteristics is essential for realistic residual strength assessments, and large test panels are required to validate complex structural designs. Built-up panels loaded to limit load levels exhibit substantial local deformation of critical elements. Failure analyses are thus dependent on elastic-plastic deflection allowables for both fastener and skin stringer elements.

Configuration factors for built-up structures for use in linear elastic fracture mechanics analyses require substantial modifications to reflect large deflections at stresses beyond yield. Load redistribution factors defining local stress fields resulting from a given amount of cracking are also required for evaluation of critical adjacent elements such as stringers or frames.

The residual strength has to equal or exceed the regulatory failsafe loads, and several failure modes must be considered. Some of the failure conditions can be determined by stress intensity factor and/or R-curve methods, depending on material ductility and fracture toughness characteristics. Interaction between net section failure behavior and elastic-

plastic element deflection constraints tend to limit traditional fracture mechanics applications, and special allowables based on extensive test verification are necessary in many instances.

Test Verification. While component tests provide valuable verification data, the specimen complexity precludes their use in developing analysis methods. Therefore, approximately 600 fracture tests on panels between 200 and 2300 mm wide containing cracks between 0.5 and 600 mm long have been conducted. Configurations tested were center cracked panels, double edge cracked panels, and panels with cracks at a fastener hole. Residual strength outside the valid range of applicable linear elastic fracture mechanics was thoroughly investigated. Effects of variables such as crack-tip configuration, load rate, and material variability also were studied. Crack growth data were obtained during the cyclic loading applied to sharpen the crack-tips.

A composite of normalized failure behavior plotted against crack length (L), normalized to the length beyond which linear elastic fracture mechanics applies (L_Y), is shown in Figure 6. An analytical representation of this behavior also is shown. The data for L/L_Y greater than unity were obtained primarily from center cracked panels fabricated from wing upper surface material, while similar data for wing lower surface materials fall in the transition region, belying their ductile behavior. The region near uncracked behavior was obtained by tests of 225 mm wide specimens containing small part-through or through thickness cracks.

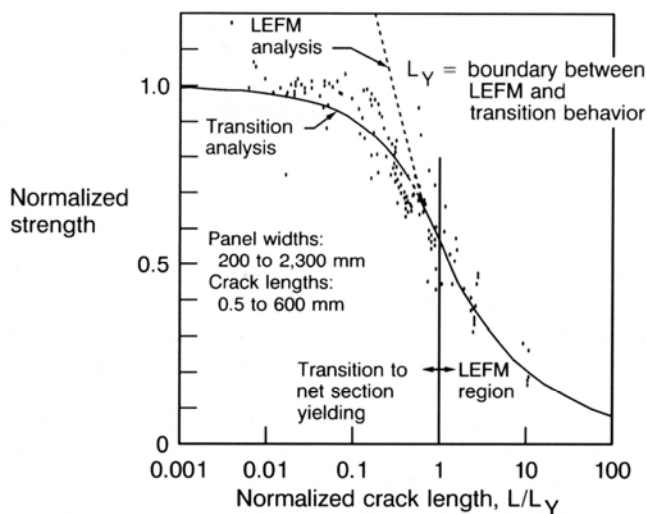

Figure 6 Residual Strength Test Verification Examples

Lessons Learned. The emphasis on residual strength verification has gradually shifted in recent years from wing structures to fuselage pressure shells. The teardowns and

testing of aging 707 airplanes in the mid 1970s were primarily concentrated on wing structures. The extended use of jet transport structures raised concerns about multiple site damage in fuselage structures and the interaction with safe decompression failure modes in the 1980s. The obvious damage per Category 2 of Figure 2 had been substantiated by test evidence and service experience for thin gages. The concern for possible influence of small undetected cracks which could influence the residual strength capability prompted modification in 1987 of technology standards to classify such lap splices as Category 3, i.e. damage detection by planned inspections. While no credit is taken for safe decompression modes in the maintenance planning, it is still a desirable design feature to provide additional protection for undetected service damage under extreme circumstances.

In 1990 Boeing completed development of two large pressure test fixtures, one with an 1800 mm radius, representing a narrow body, and one with a 3200 mm radius, representing a wide body, Figure 7. These fixtures were designed to accommodate testing for fatigue, crack growth, and residual strength of large pressure panels with a variety of structural designs and details.



Figure 7. Fuselage Pressure Test Fixtures

A typical test panel configuration is shown in Figure 8. Up to three lap splices can be accommodated and test locations can vary. Test panel frame spacing, stringer spacing, and panel radius are set by the fixture. Residual strength tests in these fixtures support the concern for MSD influence on safe decompression as discussed above.

- At locations where fatigue cracks are likely to develop in a row of fastener holes, small cracks under approximately .5 mm at all holes can significantly reduce the residual strength of a large crack in the same row of holes.

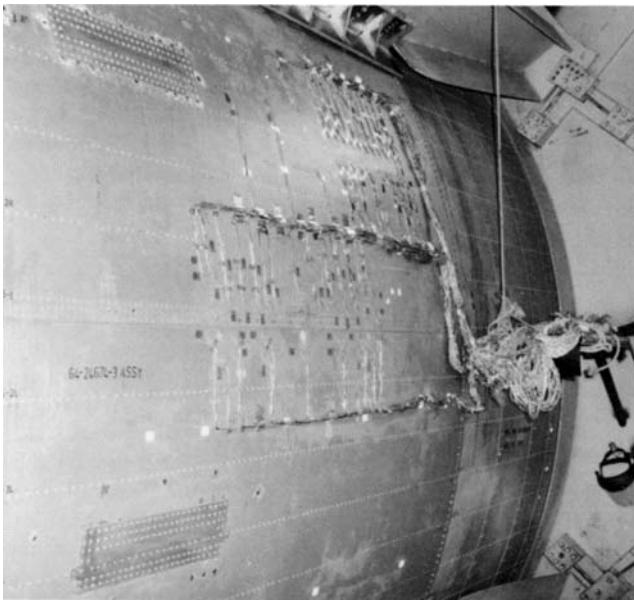
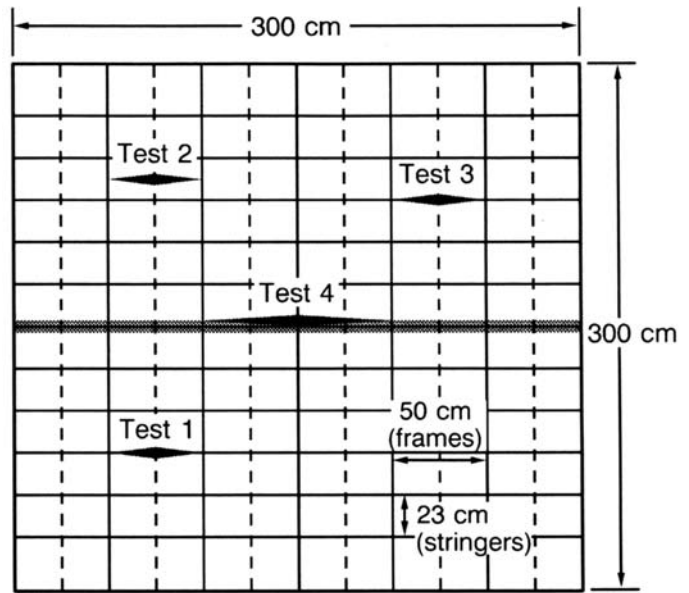

Figure 8. Typical Fuselage Pressure Test Panel



- All configurations tested, including those with MSD in adjacent holes, show the structure can safely continue at least a one-bay crack of approximately 500 mm. Configurations with at least 20% stiffening tear straps and/or full shear ties can contain a two-bay skin crack with a severed central frame. However, widespread fatigue damage in adjacent bays could reduce the size of critical cracks.
- Although all testing has shown that typical fuselage pressure structure can sustain at least a 500 mm crack, the best opportunity for safely detecting a crack in a longitudinal skin splice is before the crack reaches 25 to 50 mm. Detecting cracks in their early stages takes best advantage of the long time period (5 to 10 years) between detection and link-up. Also, as the crack becomes longer, the likelihood of widespread fatigue cracking in adjacent structure increases, resulting in reduced residual strength.
- Cracks in skin gages of 1 mm or less, reinforced with tear straps and/or shear ties, show a strong tendency to form flaps and provide safe decompression, except when the cracks appear in a row of fasteners containing a large (and perhaps unrealistic) amount of MSD. Cracks in skin gages 1.5 mm and greater have not demonstrated safe decompression by flapping/gapping.

Recent concern foraging airplane fuselage structures prompted the formation of a joint manufacturer committee on widespread fatigue damage. This group has provided definitions of multiple site and multiple element damage as well as data and processes which may be used as guidelines to identify potential critical areas for widespread fatigue damage.

The major lesson learned is that although damage at multiple sites has been addressed in residual strength analyses since the regulatory changes of FAR 25.571 in 1978, the presence

of widespread fatigue damage can significantly reduce these local damage containment areas. The safe damage detection period between the threshold of detection and limit load capability may also be reduced in the presence of widespread fatigue damage as shown in Figure 9.

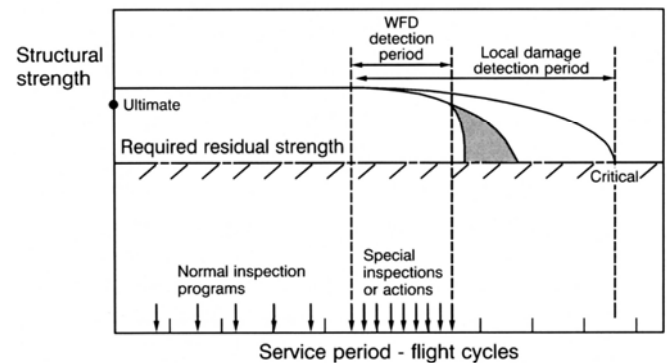

Figure 9. Damage Detection Comparisons for Local and Widespread Fatigue Damage

Crack Growth

Technology Standards. The rate of damage propagation is a function of material properties, structural configuration, environment, crack length of primary and secondary cracks, and operating stress exposure. Damage detection assessments require crack growth data from detection threshold lengths to the allowable damage determined by residual strength analyses. Use of normalized damage models for calculating relative growth per flight, including load sequence effects, permits separation of the material, geometry, and stress parameters. Solution of the G-integral for typical configurations in combination with material ratings, M, and stress ratings, S, provides the basic ingredient for efficient large-scale damage growth evaluations, Figure 10.

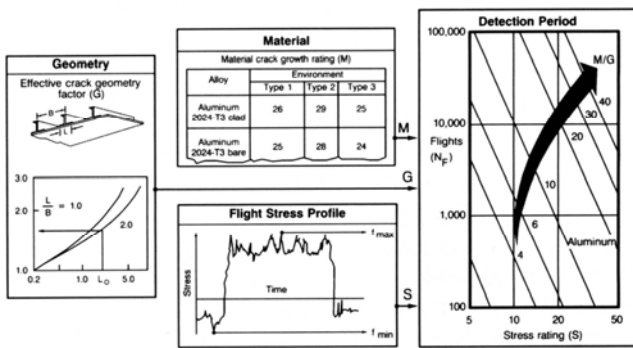

Figure 10. Crack Growth Technology Standards

The crack-tip stress intensity has proved to be the most relevant parameter for prediction of crack growth rates with any combination of stress, geometry, and crack length. The maximum stress intensity factor at a normalized minimum-to-maximum stress ratio and selected crack-tip growth rate serves as the fundamental material parameter, *M*. Typical values for different environments such as temperature, loading frequency, and humidity provide consistency in evaluating many configurations. The growth rate slope parameter is standardized for groups of alloys to facilitate comparative analyses.

Numerous stress intensity solutions are required to evaluate typical cracking patterns in primary airplane structure. Dependent and independent crack size criteria have been developed based on detailed evaluations of typical configurations and verified by teardown inspections, Figure 11. Interactive growth of these cracks from detection threshold lengths must be performed based on configuration factors accounting for parameters such as edge margins, crack eccentricity, and crack-tip proximity to stress concentrations. A technique involving unit stress solutions is used to obtain equivalent stress intensities between initial and final crack lengths. These *G*-factors provide a convenient summary of more complex analyses performed once and assist the analysis with a quantitative measure for comparison of different cracking patterns.

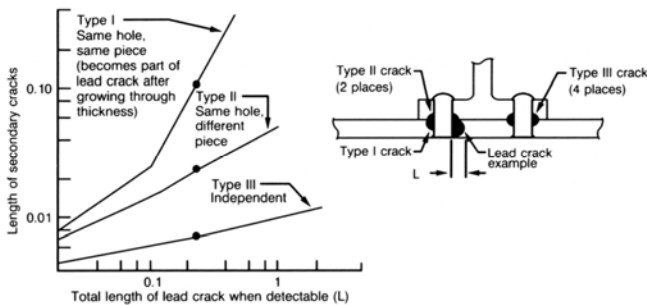

Figure 11. Multiple Site Damage (MSD) Size Analysis Guidelines

Operating load conditions and spectra are defined for short, medium, and long flights. Normalized spectrum crack growth evaluations are performed once on a flight-by-flight basis for fixed *M/G* values and based on damage models reflecting growth rates at different combinations of

alternating and mean crack-tip stress intensities. This eliminates repetitive cycle-by-cycle calculations for each combination of structural configuration, material, and crack length. Load sequence effects based on effective overload and under load stresses provide retardation-acceleration phenomena peculiar to jet transport loading spectra. The crack stress rating, *S*, collapses both spectrum and load sequence effects into an allowable operating stress for a given growth period and normalized *M/G* values.

Test Verification. Basic material crack growth properties are obtained from the constant amplitude loaded center cracked panels. These properties can be used directly in crack growth analyses if the assumption of linear accommodation of damage can be made. However, variation of operating stresses between flight segments and/or flights can cause significant acceleration or retardation of the crack growth rate when compared with the results of a linear analysis. Extensive test programs have been undertaken to study this phenomenon.

Impetus for the development of representative load spectra arose from the need to conduct full-scale tests under realistic conditions in the early 1980s. During the development process, certain compromises were necessary due to limitations of time and test equipment. To ensure that the spectra remained representative, a parallel series of spectra were developed for small-scale specimen tests to investigate the effects of load truncation levels, omission levels, and flight types.

Load spectra for about ten typical locations on three different Boeing commercial jet transports were developed for this initial verification test program. Three basic test spectra, varying in the degree of service load simulation, were developed for each location. Figure 12. Eight segments are identified within a flight and consist of ground and flight events. The equivalent cycle or 1x1 spectrum is a single repeated flight consisting of one or more cycles of the same magnitude in each of the eight individual segments. The magnitude of the cycles is approximately the same as the once-per-flight load for that segment. The number of cycles was selected to give damage, based on simple linear analysis, similar to damage predicted for the segment by the more complicated load spectra.

| Spectrum type | Spectrum loaded segments | Spectrum load levels | Average cycles per flight | Flight types |
|---------------|---|----------------------|---------------------------|--------------|
| 10 x 5,000 | <ul style="list-style-type: none"> Half cycles selected at random (peak follows valley) Sequence of segment severity selected at random | 8 per flight | 10 per segment | 5,000 |
| 5 x 5 | <ul style="list-style-type: none"> Half cycles selected at random (peak follows valley) Distribution of flight types selected at random | 8 per flight | 5 per segment | 5 |
| 1 x 1 | <ul style="list-style-type: none"> Load magnitudes selected at once-per-flight occurrence level | 8 per flight | 1 per segment | 1 |

▶ More than 10 repeated load sequences per design service objective.

Figure 12. Test Spectra Characteristics

The 5x5 and 10x5,000 spectra are random flight-by-flight test spectra that differ in the degree of randomization and the extent of low load omission and clipping levels. These spectra were developed using the same statistical criteria as the Transport Wing Standard Spectrum (TWIST) with special modifications that tailor the gust, flight, and ground load spectra for use on Boeing jet transport fatigue and crack growth evaluations. The 5x5 spectrum consists of five flight types randomly sequenced in repeated one-tenth lifetime blocks of flights. Five load levels are used in each segment of the spectrum to represent service usage. Examples of the flight types are shown for model 767 wing lower surfaces in Figure 13. Each flight consists of 50 load cycles on average. The 10x5,000 spectrum includes approximately twice as many cycles as the 5x5 spectrum and can use as many as ten load levels within a single segment.

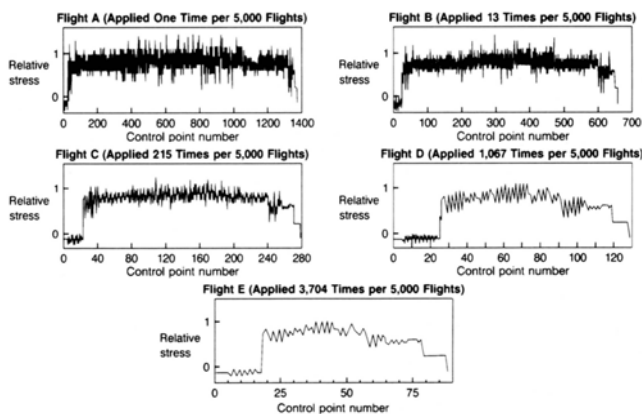

Figure 13. Wing Lower Surface Spectrum Example

Crack growth as a function of spectrum complexity is shown in Figure 14 for 2324-T39 plate specimens containing a central crack subjected to spectra representing loads on the wing lower surface of a commercial jet transport. Each of the three spectra was developed to produce the same damage based on an assumption of linear damage accumulation using constant amplitude test data. Crack lengths in most specimens were measured using two pairs of overlapping crack gages attached to opposite faces of the test specimen. Crack growth rates for the most sophisticated 10x5,000 spectrum and the simpler 5x5 spectrum are similar at all crack lengths. The crack in the specimen subjected to the 1x1 spectrum grew significantly faster at all crack lengths indicating that extensive simplification of a full spectrum of flight loads can produce misleading results. The relative crack growth performance of 2324-T39 plate specimens containing a central crack subjected to constant amplitude loading is shown in Figure 15. Each of the three specimens was machined from the same basic plate to a different thickness, nominally at the mid-plane of the plate stock. It can be observed that crack growth rates tend to decrease with decreased thickness. However, there is little difference at short crack lengths in the thinner gages. The relative performance for center cracked specimens of the same material and thickness, subjected to a wing lower surface spectrum, is also shown in this figure. A more consistent decrease in crack growth rate with decreased

thickness can be observed. It is apparent that the influence of thickness is greatly enhanced under variable amplitude loading conditions.

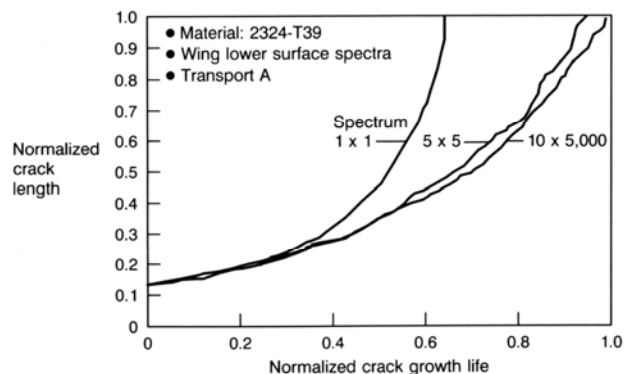

Figure 14. Effect of Spectrum Complexity on Crack Growth

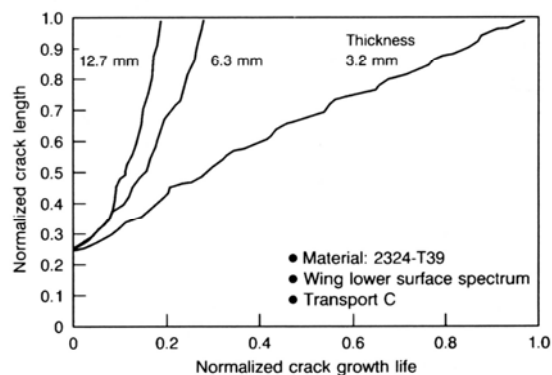
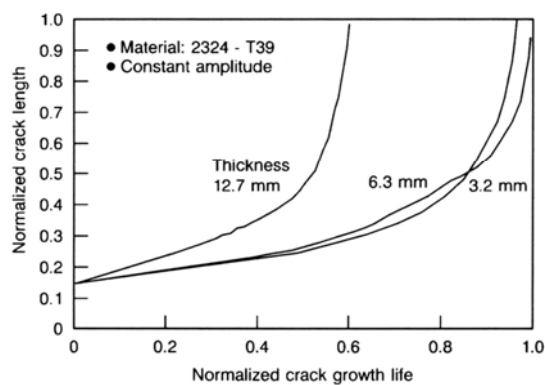

Figure 15. Thickness Effect of 2324 Aluminum Crack Growth

Lessons Learned. It is impossible to conduct realistic tests on each structural configuration or cracking pattern. It is also impractical to perform cycle-by-cycle crack growth rate analysis for each cracking pattern. To enable the structural evaluation process to proceed in a timely manner, Boeing uses a twofold approach to perform crack growth analyses on primary structure subjected to spectrum loads. A standard large-scale analysis approach separates the main variables of stress, crack length, and material properties. A cycle-by-cycle analysis program, based on crack opening models, is used to support refinement of the standard model. This program is used in limited applications of fleet data analysis,

test comparison, verification of the accuracy of the simpler standard analysis, and methods development.

Accurate prediction of crack growth under airplane spectrum loading is a challenging task. Interaction effects due to variable amplitude loading during crack growth are well known. Additional requirements to include environmental effects, transition between plane strain and plane stress and possible changes of the crack growth mechanism for small cracks make predictions more difficult. The tasks of understanding these effects and of developing practical and efficient analytical models for crack growth prediction induced by variable amplitude loading have received increased attention over the past several years. Standardized flight-by-flight test spectra modeled after the TWIST spectrum have proven valuable for representative full-scale fatigue tests and verification test programs. The retardation/acceleration effects have substantially influenced the maintenance planning for fatigue damage detection in new and aging airplanes.

Multiple site damage concerns discussed previously under residual strength also prompted revisions of the technology standards in 1986 to address link-up of small cracks in fuselage lap joints. Data from lap splice and pressure dome testing demonstrated rapid link-up after the initial connection between two adjacent holes, Figure 16. This analysis approach was later incorporated in revisions of supplemental inspection programs. Subsequent testing of a 737 fuselage retired from service provided additional verification of the link-up process.

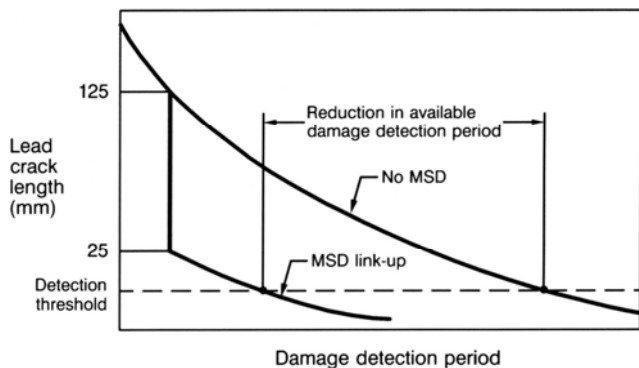

Figure 16. Multiple Site Damage Link-Up Effects on Detection Period

Testing of new airplane structures does not incorporate corrosion and/or accidental damage that can accelerate fatigue cracking. Similar tests are conducted on older airframes to gain insight into the problems that might be experienced on high-time airplanes with repairs and service-caused defects. Extensive pressure testing was conducted on 737 and 747 teardown airplanes to simulate the effects of additional flight cycles.

The effect of MSD on damage tolerance was evaluated by fatigue testing of a retired 737 aft fuselage in 1987. After 59,000 service flights, the fuselage test section was cycled until normal fatigue cracking had begun and grown to its

natural conclusion of a two-bay crack with safe decompression by flapping. The loss of damage detection by rapid link-up is illustrated by Figure 17, and compares well with the link-up assumed in technology standards per Figure 16. In this test, MSD was present in adjacent holes and in adjacent frame bays with a nonuniform distribution of crack sizes typical of fatigue scatter. Although the test may not represent the worst case of fatigue scatter and MSD, it is reasonable to assume that the test results do represent typical performance.

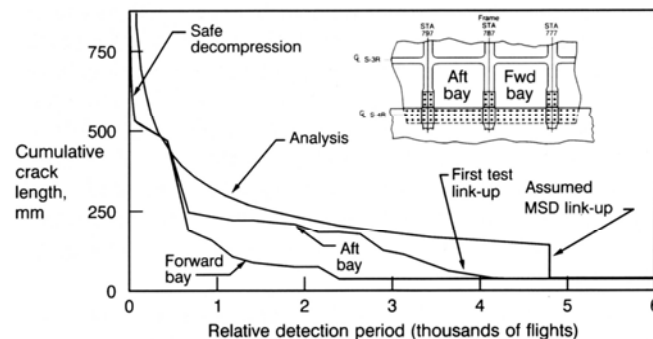

Figure 17. Test and Analysis Crack Growth Comparison for Fuselage Lap Splice with MSD Link-Up

Decompression by flapping is not relied on as a safety factor in the case of cracks in lap splices as discussed earlier. Rather, inspection programs must be in place to ensure crack detections before link-up. In the test described above, a 12 year damage detection period between initial detection and link-up was indicated assuming 3,000 flights per year. According to further experience on a fully disbanded in-service airplane, that number would be reduced to six years, still ample time for detection.

A 747-100SR with an equivalent of 20,000 full pressure cycles (flights) was obtained from service and monitored as the fuselage was pressure tested to 40,000 cycles. An initial crack was detected in the lap splice in S14R at 21,500 cycles. This crack eventually linked up with other small cracks and grew to approximately 150 mm by the time the test was concluded at 40,000 cycles, Figure 18. Assuming 1,500 flights per year of normal operations, the crack growth data from this test indicate a 7 year damage detection period before link-up. After link-up, tests indicate there is a significant, additional safe damage detection period.

Sections 41 and 42 from the 747-400 production line were also pressure cycled to determine some of the fatigue and damage tolerance characteristics of the latest production configurations. Cracks eventually started at several locations, 747-100SR, Figure 19. Recorded crack growth data indicate a long damage detection period between the time of detection and link-up, possibly longer than 10 years for an airplane making 1,000 normal operation flights per year. These test results show reasonable correlation with the link-up criteria previously discussed.

The data also show that the 747-400 fuselage section is capable of supporting a one-bay crack, providing an additional safe crack detection period.

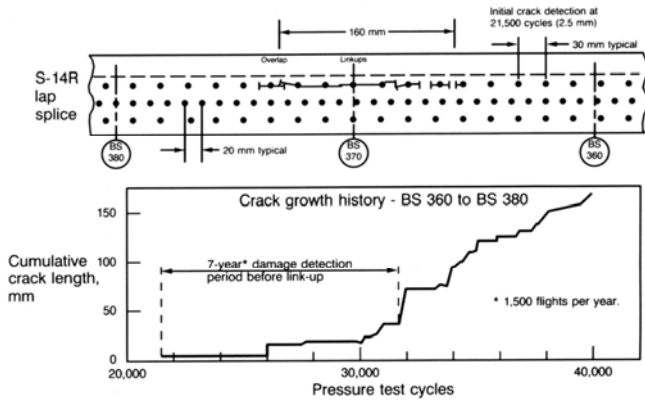

Figure 18. 747-100SR Fuselage Lap Splice Test Results — Stringer 14L

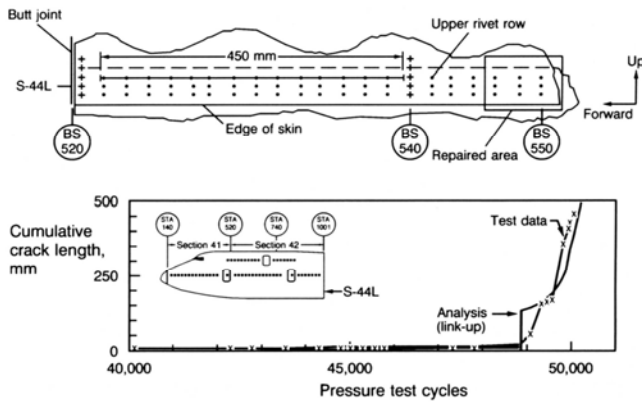

Figure 19. 747-400 Fuselage Lap Splice Test Results — Stringer 44L

Damage Detection

Technology Standards. Three principal sources of damage to airplane structure must be considered independently, Figure 3. Both accidental damage and most forms of environmental damage can be considered random events that can occur at any time during the operational life of an airplane. Fatigue damage is characterized by cumulative progression relating to airplane usage measure in flights. Detection ratings have been developed for accidental and environmental damage. A quantitative fatigue damage detection rating system developed by Boeing is known as the Damage Tolerance Rating (DTR) system. The concepts of this system have been described in earlier publications and this review focuses on application examples that demonstrate major features.

Damage detection is a function of fleet size, the number of cracks, and the number and type of inspections. Three independent probabilities determine the certainty of damage detection:

- P_1 : probability of inspecting an airplane with damage

- P_2 : probability of inspecting a detail containing a crack
- P_3 : probability of detecting a crack in the detail

For a single inspection of the detail considered on an airplane with damage, the probability of detection P_3 is a function of crack length, inspection check level, and detection method.

P_3 for visual inspections is based on an extensive review and analysis of fatigue cracks detected in service. Account has been taken of cracks remaining undetected during inspections prior to detection including those assumed to have occurred but not yet detected, Figure 20. Detection thresholds and characteristic crack lengths are defined by a three-parameter Weibull distribution.

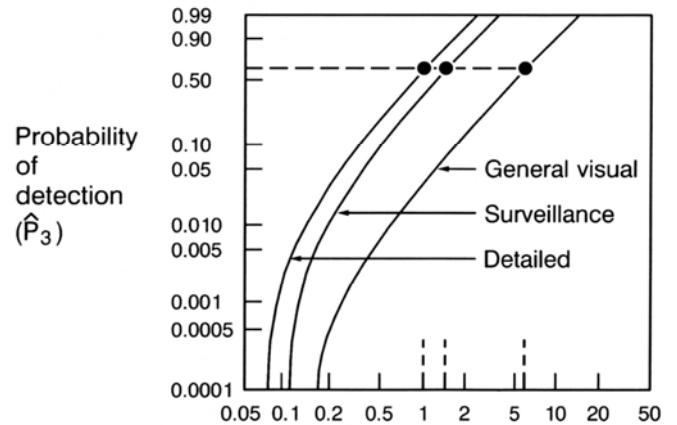

Figure 20. Relative Probability of Detection for Visual Inspection Methods

Use of nondestructive inspection (NDI) procedures such as ultrasonic or low frequency eddy current may significantly increase the damage detection period, Figure 21. NDI procedures allow detection of smaller surface cracks than with visual inspection and also allow sub-surface crack detection. Therefore, an equal probability of detecting damage can be achieved with a reduced inspection frequency. Damage detection reliabilities have been established for different crack lengths in relation to the minimum detectable for typical inspection techniques and structural configurations, Figure 22. These P_3 curves are appropriately modified to account for visual detection of surface cracks and multiple probe applications at different locations along the same crack during the same inspection of subsurface cracks.

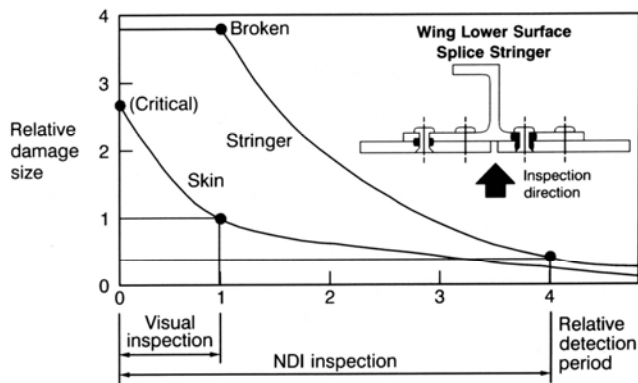

Figure 21. Visual Versus NDI Damage Detection Periods

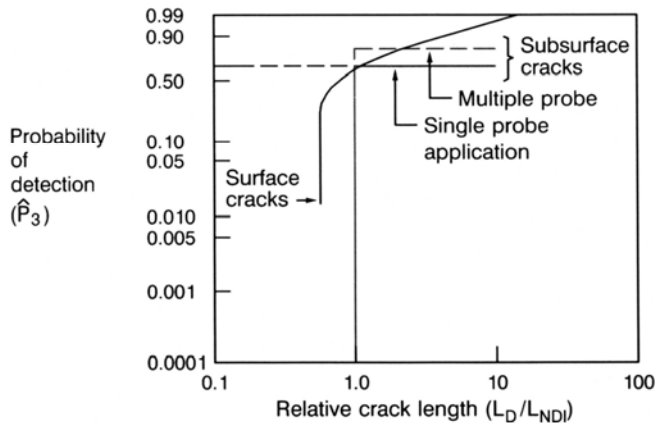

Figure 22. Probability of Detection for NDI Inspections

Crack length at the time of inspection is random. The last inspection occurs at some point during the final inspection interval, \bar{N} , Figure 23. Since P_3 varies significantly, the average value is determined by integrating individual P_3 over the interval. Previous inspection detection contributions can be approximated by the P_3 values for the midpoints of each inspection interval. The cumulative probability of crack detection in at least one of several inspections is $P_3 = 1 - \prod(1 - \hat{P}_{3j})$. In some cases the inspection interval \bar{N} is greater than the damage detection period, N_0 , and the probability that the inspection will occur is accounted for by calculating the average \hat{P}_3 for the inspection interval assumed equal to N_0 and using $P_3 = \hat{P}_3 N_0 / \bar{N}$ for damage detection assessments.

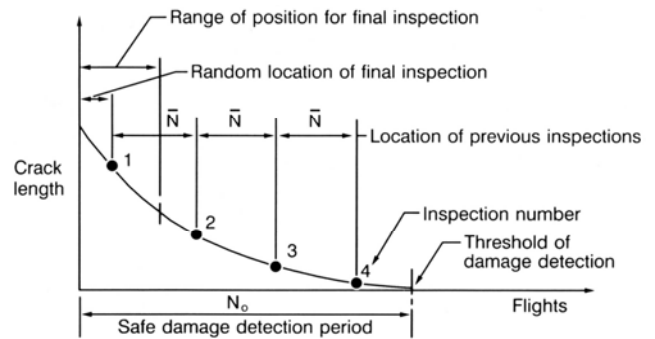

Figure 23. Multiple Inspection Detection Consideration

The calculated probability of detection does not provide a convenient measure of maintenance actions and requires products of non-detection probabilities to combine effects of types and/or levels of inspections. The DTR is a measure of detecting at least one fatigue crack. The measuring units are the equivalent number of opportunities for detection, each with an equal chance of detection or non-detection:

$$P_D = 1 - \frac{1}{2^{DTR}}$$

$$P_D = 1 - \prod(1 - P_{di})$$

$$P_{di} = P_1 P_2 P_3 \text{ for all applicable inspections}$$

The measurement of detectability by DTR values provides a better comparison between P_D levels on a suitable engineering scale, Figure 24. The detection evaluation can be performed for varying inspection intervals and methods which are summarized on a form suitable for individual operator use, Figure 25.

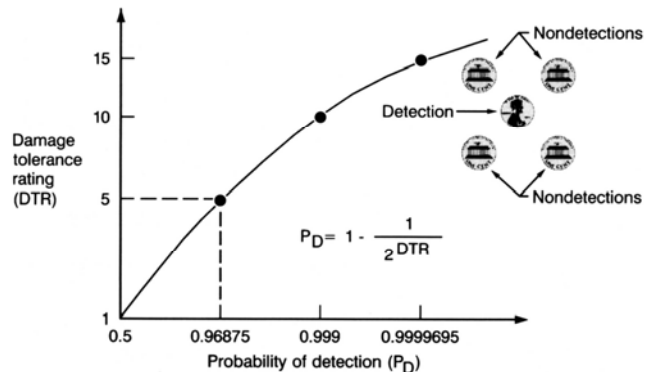

Figure 24. Probability of Detection Measurements

| DTR CHECK FORM | | ITEM | W-XX | MODEL-SERIES | | | | |
|---|----------------------------|---|----------------|--------------|----------------------|---|------------------|---------------------|
| TITLE: WING LOWER SURFACE REAR SPAR CHORD AND SKIN | | OPERATOR(S) | NO OF CAND A/C | 7X7-XXX | | | | |
| LOCATION: | | EXAMPLE | XX | | | | | |
| | | STRUCTURE AND INSPECTION DETAILS LEAD CRACK SKIN FLANGE OF CHORD | | | | | | |
| NOTES: | | | | | | | | |
| STRUCTURE DETAIL | INSPECTION PROGRAM DETAILS | | | | | DAMAGE DETECTION PERIOD N _D FLIGHTS | Δ DTR | |
| | JOB CARD | DIREC | CHECK LEVEL | METHOD | %SAMP R _D | | | FREQUENCY F FLIGHTS |
| SKIN | | 1 | C | SURV | 100 | 3000 | 3000 | 3.3 |
| SPAR CHORD | | 3 | | LFEC | | | | |
| DATA CONTROL: (A) INDIVIDUAL OPERATOR (B) FUEL LEAK DTR | | | | | | | 2 | |
| (B) BOEING (J) JOINT BOEING/ALL OPERATORS | | | | | | | TOTAL DTR | 5.3 |
| (R) JOINT BOEING/REGULATORY AGENCY | | | | | | | (R) REQUIRED DTR | 4 |

Figure 25. Damage Tolerance Rating Check Form for Detection Assessments

Required DTR levels have been established using engineering judgment of cracking circumstances and the probability of actually having a safety-critical crack. Detection opportunities for long crack lengths, whose residual strength capabilities are less than or equal to limit load, are not included in DTR evaluation. In addition, it is assumed that fatigue cracks always start in the worst location for detection. A study of reported cracking data shows that many cracks are detected during activities not directly related to structural inspections. These additional opportunities for detection are not used in the DTR evaluations. This background was used to establish a basic required DTR value of 4. Increments to the basic required DTR were established by a quantitative assessment of detection opportunities and the level and frequency of fail-safe stress compared with normal operating stress, Figure 26.

| Required detection reliability | | | |
|--------------------------------|---|-------------------------------------|--|
| Structure | | Cumulative detection probability, % | Equivalent detection opportunities (DTR) |
| Wing and nacelles | Externally visible areas | 94 | 4 |
| | Areas not externally visible | 98 | 6 |
| | Primary flap structure | 99 | 8 |
| Empennage | Primary structure | 98 | 6 |
| Fuselage | Contribution of cabin differential pressure to total fail-safe stress | < 50% | 98 |
| | | ≥ 50% | 99.9 |

Figure 26. Required Damage Detection Reliability (DTR)

Verification. Service cracking reports form the foundation of the DTR system. Several sources covering more than two decades of jet operations have been used. The Mechanical

Reliability Reports (MRR) and Service Difficulty Reports (SDR), submitted by the operators to the Federal Aviation Administration and a Boeing internal Significant Item Report System (SIRS), have been used in an empirical evaluation of many of the parameters. The SIRS system contained over 35,000 events at the time of detection assessments in the early 1980s, and more than 7,700 related to structural fatigue. This information was used to isolate data with known crack length for areas with no prior cracking history in specific details, Figure 27. The distribution between directed and non-directed inspections was also accounted for. The MRR/SDR data base contained about 3,500 structural fatigue events and proved to be similar in most respects to the SIRS. The majority of cracks are found visually during non-directed inspections, Figure 28.

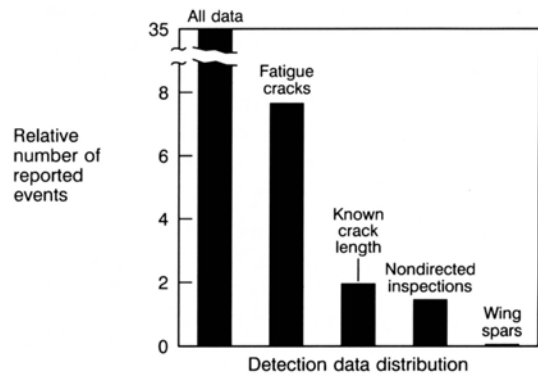

Figure 27. Relative Inspection Data Distributions

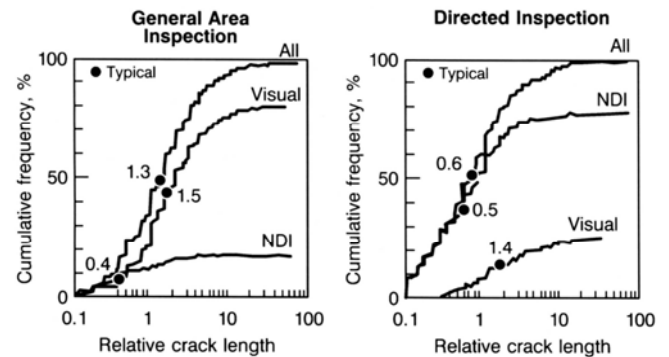

Figure 28. Distribution of Cracks Found in Service

Detection standards used for fleet safety evaluations must recognize that many service inspections fail to detect damage beyond the detection threshold. A mean crack growth curve shape was used to describe the crack growth history prior to detection. Crack length, total flights at detection, and an assumed detection threshold after an appropriate period of service provided the necessary crack growth curve constants. Figure 29. Previous unsuccessful inspections correspond to non-detections that usually are 20 to 50 times more numerous than the detection events. Allowance was made for escalation in inspection intervals for the relevant period of collected service data and for cracks currently being missed that will be detected in the future. This latter point was demonstrated by successive

elimination of detection events and analysis of the reduced sample. The total influence of the non-detection events is substantial as illustrated in Figure 30.

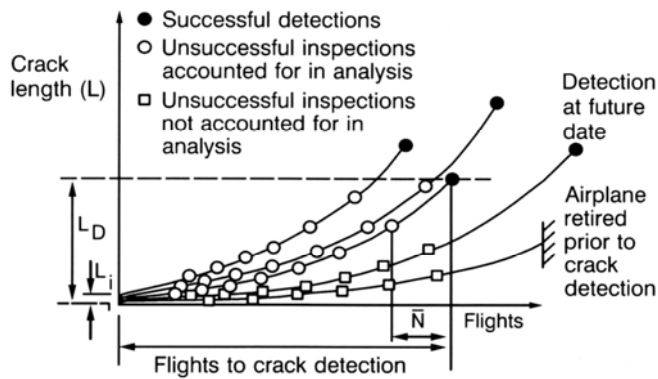

Figure 29. Detection and Nondetection Events

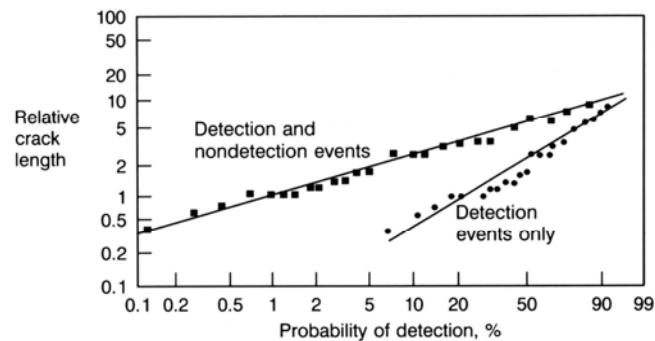

Figure 30. Effect of Nondetection Events on Probability of Detection

A three-parameter Weibull distribution is used to describe visual detection standards and provides satisfactory fits over the central range of crack lengths. Some censoring of data is necessary because detection events at long crack lengths can cause considerable deviation of the data from linearity on a log-Weibull plot. Censoring of these detection events can be justified on physical grounds because:

- Long cracks grow rapidly with airplane usage.
- Length at detection is strongly influenced by the precise moment of inspection.
- Few non-detection events occur at long lengths.
- A small portion of the total detection sample occurs at long lengths.

The probability of crack detection as a consequence of a fuel leak was developed by evaluating cracks of known length reported in wet bay areas. Cracks found by fuel leak were isolated from those for which no leak was reported. The resulting sample of leaks and non-leaks was characterized using a Weibull distribution to give the probability of detecting a crack by fuel leakage as a function of crack length, Figure 31.

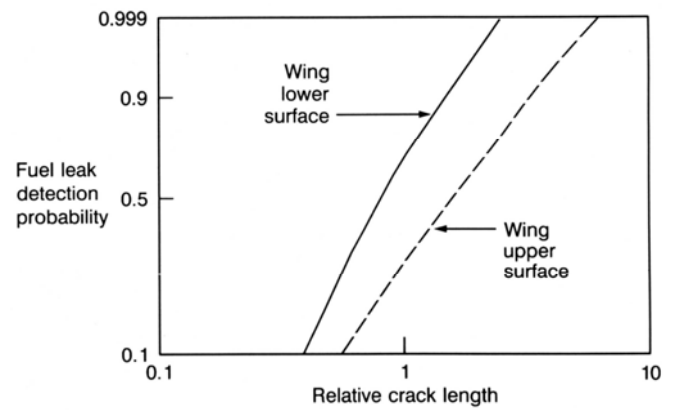

Figure 31. Probability of Fuel Leak Detection

Lessons Learned. The visual detection standards used by Boeing are based on a large fleet data base. Recognition of non-detection events significantly increases detectable damage sizes as illustrated previously in Figure 30. Subsequent experience with the DTR system to establish supplemental structural inspections has indicated that these detection standards do reflect existing maintenance practices. A further proof are the feasibility studies for fatigue inspections conducted for models 757 and 767 in the early 1980s. These programs emerged similar to past experience which would not have been the case for poorly calibrated detection standards.

Structural maintenance and inspections are cornerstones of continuing airworthiness of jet transport structures. While nondestructive inspection (NDI) procedures have evolved significantly in recent years, it is imperative to note that initial structural distress is usually detected visually as shown previously in Figure 28. NDI has a significant role to play for proper surveillance of known service problems. Vigilance must be maintained to ensure that future jet transports are designed robust enough to mainly rely of visual inspections for initial damage detection.

Aging fleet related research programs have in recent years been dominated by NDI projects. These efforts may result in some significant enhancements in damage characterization for monotonous inspections of large sections of fuselage splices, etc. Similar emphasis should also be placed to visual inspections to gain more industrywide and uniform damage detection standards. While this work may lack the engineering elegance of NDI research and rather be based on tedious reviews of reported service data, it is of imperative importance for development of rational inspection programs.

Several research centers have received congressional funding to address NDI technology. Care must be exercised in these studies to characterize probability of detection (POD) data as primarily reflecting the equipment capability. The human factors are difficult to simulate in the laboratory and require continuing evaluations of reported service data. This will in the long run allow proper recognition of non-detection events and thus provide more rational detection standards which also properly recognize the visual detection contribution for surface cracks.

Widespread fatigue damage of similar and identically loaded structural elements can significantly affect the residual strength of the structure. There are several industry task forces addressing these issues with a close link to inspection requirements. Airplanes exceeding design service objectives will require more detailed and intense inspections/selective teardowns than typically expected in the past. While visual inspections are significant, the widespread fatigue damage will require continued diligence in developing practical NDI procedures.

STRUCTURAL MAINTENANCE CONSIDERATIONS

Structural maintenance and inspections are the cornerstones of continuing airworthiness of jet transport structures. The advent of fracture mechanics technology has accelerated the knowledge for determination of crack growth rates and maximum allowable damage at limit load conditions. The research community has expanded the understanding and modeling of these structural characteristics. While elastic-plastic analyses have their place, the added accuracy is often not consistent with the accuracy of other significant parameters governing residual strength. Significant understanding exists today to properly plan fatigue and crack growth tests in order to recognize sequence effects caused by spectrum loads. While analysis models can yield reasonable correlation with laboratory loading environments and simplified structural configurations, it is easy to have large uncertainties due to local load redistributions in cracked structures, flaw shapes, cracking patterns and a host of external and environmental characterization problems. While progress must be encouraged, it is truly necessary to pay attention to the overall sensitivity of stress histories and analysis assumptions on the final answer. In summary, prediction of fatigue crack growth for a host of complex structural details within a factor of two is not always as easy as advertised by complex models.

The practicing structural maintenance engineer is charged with development of inspection programs from the time of airplane introduction into service. Three principle forms of structural damage must be evaluated to achieve a balanced structural inspection program, Figure 32, for timely detection of environmental deterioration, accidental damage, and fatigue damage.

| Damage phase | Principal inspection planning parameters | | |
|--------------|--|---|---|
| | Fatigue | Environmental deterioration | Accidental |
| Initiation | <ul style="list-style-type: none"> • Design quality • Cyclic stress • Operating environment • Flight cycles | <ul style="list-style-type: none"> • Corrosion <ul style="list-style-type: none"> - Operating environment - Protective system • Stress corrosion <ul style="list-style-type: none"> - Material sensitivity - Sustained stress | <ul style="list-style-type: none"> • Random discrete event from a cause not normally encountered during fleet operations |
| Growth | <ul style="list-style-type: none"> • Material • Geometry • Cyclic stress • Environment • Flight cycles/ hours | <ul style="list-style-type: none"> • Extent of conditions that caused damage initiation • May result in subsequent crack growth if not detected and repaired | <ul style="list-style-type: none"> • May result in subsequent crack growth if not detected and repaired |

Figure 32. Inspection Planning Considerations

Environmental deterioration actually involves two forms of damage, corrosion and stress corrosion. Corrosion may or may not be time- and/or usage-dependent. For example, deterioration resulting from a breakdown in a surface protection system is more probable as calendar age, increases; conversely, corrosion due to spillage or a leaking seal is treated as a random discrete event.

Accidental damage can also be considered in two categories. First, discrete source or large-scale damage, such as that caused by a large bird strike or uncontained engine

disintegration, involves special regulations. Such damage detection is considered obvious, but it must be shown that a flight can be safely completed after it has occurred. Second, more general forms of accidental damage, such as dents and scratches, occurring during routine operation of the airplane must be considered in the inspection program.

Both accidental and most forms of environmental damage are random events that can occur at any time during the operation life of an airplane. However, experience has shown that some structural areas are more susceptible than other to these types of damage. This information is used to develop suitable inspection tasks.

Fatigue damage is characterized as the initiation of a crack, with subsequent propagation. This is a result of a continuous process whose effect is cumulative with respect to airplane usage (measured in flights or flight-hours). Comprehensive fatigue life, crack growth and residual strength evaluations are required. Using previous service experience to improve detail design results in a high level of structural durability. Large-scale panels and full-scale airplane fatigue tests are used to identify areas in which this durability is significantly lower than predicted. Changes to the production airplanes to rectify problems usually result. Most airplanes in the fleet are then expected to exceed the fatigue service objective without significant cracking. This does not preclude anticipated cracking before all airplanes reach the design life objective.

For safety critical structures, it must be demonstrated that there is a high probability of timely detection of any cracking throughout the operational life of the fleet, Figure 1. This means that the inspection program must be capable of timely detection of initial damage in the fleet. Subsequent action is necessary to detect or prevent any damage in the fleet.

The conflicts in structural maintenance planning often occur because the focus on fracture mechanics based damage tolerance evaluations. Inspection programs in place to provide timely detection of corrosive or accidental damage are often not addressed by the scientifically oriented structural engineer who may be satisfied with inspection thresholds based on universally applied initial flaws and inspection intervals based on simple factoring of the damage detection period from an assumed detectable/inspectable damage size to the damage allowed at limit load conditions.

This section addresses some key issues related to inspection thresholds and intervals with emphasis on quantifying detection reliability aspects and sensitivity to key parameters and variables.

Inspection Thresholds

Environmental deterioration and accidental damage are random events that can occur at any time, Figure 33. Inspection requirements related to these damage sources apply to all airplanes in the fleet. The threshold for inspection is the first scheduled maintenance check interval

corresponding to the repeat interval determined for the structure. For example, if the repeat inspection interval for a particular structural item is a C-check (typical annual inspection interval), the first inspection corresponds to the first C-check on each airplane. Additional emphasis on corrosion prevention and control measures due to aging fleet concerns with combined fatigue and corrosion damage have also prompted more stringent inspection and prevention measures discussed in a later section.

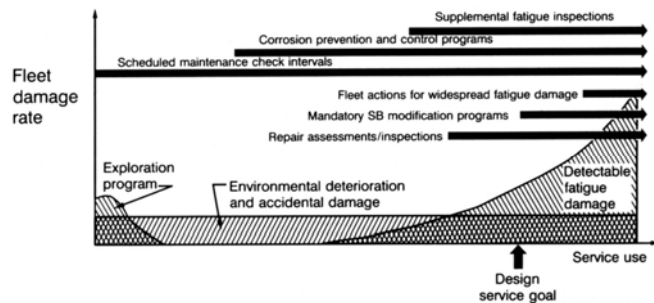

Figure 33. Fleet Damage and Maintenance Program Phases

Corrosion caused by breakdown of a protective surface in the presence of an adverse environment can vary significantly between operators. There can also be significant differences in corrosion initiation and rate of growth as a consequence of geographic location, type of cargo, and other factors. The most efficient way for each operator to determine its particular threshold is an age-exploration program. This generally involves inspecting selected structural details at a fixed repeat interval on a rotating portion of the fleet. Age-exploration allows an operator to gradually check difficult-to-access structure on all airplanes. All operators are notified if any operator reports signs of structural distress to the manufacturer and regulatory authorities as required. This generally results in full fleet inspections and/or preventive repair or modification initiatives.

Fatigue Damage. Fatigue cracking can be anticipated in a large fleet of airplanes even when the structure meets the design objective. For example, consider a structure designed with 95% service objective reliability. In a fleet of 500 airplanes, 475 can be expected to exceed the design service objective and 200 exceed twice this life without cracking. Conversely, up to 25 airplanes may be cracked by the time the fleet has reached the design service objective. More important, the first crack can occur as early as midway into the design service objective. Because cracking order is randomly distributed within the fleet, it is unlikely that the first airplane to reach mid-life will be cracked. However, mid-life appears to be a reasonable threshold for the most critical structure designed to prudent durability requirements.

A variable threshold can be defined where routine inspections provide some opportunity for detecting fatigue damage. This will also make implementation of supplemental fatigue inspections more manageable and

avoid a sudden increase. The rate of cracking of identical structural components in a fleet of airplanes is another parameter that can be predicted. This prediction, coupled with multiple inspections, significantly influences the probability of timely detection of fatigue damage.

Fatigue cracking that occurs earlier than anticipated is generally caused by conditions not identified by analyses and/or tests. Examples are additional loads or higher loads than expected, locally higher stresses, or interaction of loads from various sources. In many cases, the unanticipated cracking is caused by a set of circumstances on only one or a few airplanes. These types of cracking generally occur relatively early in the life of the airplane, and associated dependent multiple site cracking is unlikely, resulting in correspondingly higher residual strength and crack stopping capability. Such single element cracking is similar to the cracking that may follow accidental damage and the inspection requirements can therefore be similar.

Traditional fatigue analyses provide one source for estimating the threshold of initial fatigue cracking in a fleet of airplanes. The reliability of such estimates is dependent on applicable full-scale test evidence. The posture during the fail-safe era of commercial jet transport design and operation and prior to the emerging aging fleet challenge was to conduct full-scale tests for local areas that may exhibit early fatigue problems. Such tests were not designed to demonstrate safe-life limits of failsafe structures and not an alternative to the inspections required to ensure continued structural airworthiness. Increasing concerns for widespread fatigue damages has promulgated more pressure to establish thresholds for such type of structural damage which can significantly reduce the residual strength and accelerate damage progression through link-up of adjacent cracks.

Full-Scale Fatigue Test Evidence. Traditionally Boeing and other manufacturers conduct full-scale fatigue tests of new models for economic reasons, to locate areas that may exhibit early cracking in service and to correct such hot spots. Single airplane full-scale fatigue testing provides useful data but can not adequately represent the variety of operating conditions and structural details in a large fleet of airplanes subject to corrosion and/or accidental damage. Inferences of an operational life limit based on fatigue test by pending regulatory actions is disturbing. Fleet safety stems from design and certification of damage tolerant structure, coupled with diligent inspection, repair and/or modification throughout the airplane service use. As mandatory fatigue test requirements for new models are pursued, several major issues must be addressed, including criteria for performance expectations, timing of fatigue test completion, and its relationship to type certification.

Several strong objections can be raised to sometimes proposed retroactive requirements for fatigue testing of previously certified models. Such testing after accumulation of long service periods is not a rational way to address structural safety concerns for several derivative model/series combinations. Single airplane testing cannot simulate typical structural damage sources and operating conditions which

occur in service. The FAA is advocating that fatigue testing will address possible multiple site damage threshold concerns which may invalidate original expectations and principles to which these aging airplanes were designed. Supplemental structural inspection programs for high time airplanes developed in the late 1970s incorporate substantial multiple site damage considerations in structural reassessments. There is nevertheless strong impetus to conduct new model full-scale fatigue tests to establish basic performance characteristics which provide one of many considerations for selecting widespread fatigue damage thresholds.

FAA mandated inspections of principal structural elements on hundreds of in-service high time airplanes in their total real operating environment provide a much more realistic and effective structural fatigue assessment than a single full-scale test. In summary, fatigue testing does not guarantee fleet safety and is not a substitute for diligent operator inspection, maintenance and repair actions. While fatigue testing of new models provides useful data in the early portion of expected service life, the industry has good reasons to strongly object to operational life limits tied to such testing. Retroactive fatigue tests for long term service airplanes is of limited value in comparison with life margins demonstrated by the fleet.

Fatigue Inspection Thresholds. Structural fatigue evaluations of early Boeing commercial jet transports depended heavily on experience, engineering judgment and

tests during the design and analysis process. As technology progressed and competitive pressures for long life economic structures increased, fatigue specialists were forced to apply more sophisticated analysis methods. However, the timing of such evaluations was often incompatible with the detail design and drawing release process since fatigue evaluations involved time consuming analyses and lacked visibility of key parameters. Logistics involved in managing large teams of structures engineers to effectively utilize cumulative design experience and apply disciplined fatigue methods prompted development of durability technology standards in the early 1970s. The key elements of this system are:

- Retention of test and service experience.
- Durability design guides.
- Quantitative fatigue analysis methods and allowables.

The design service objectives are established for high utilization operators in terms of flight cycles for short, medium and long flights. Design service objectives are established with a minimum of 95% reliability. For typical aluminum alloys this implies a characteristic life of at least twice the design service objective excluding additional factors applied to achieve 99% reliability for most principal structural elements. Supplemental structural inspection based on fatigue principles are often initiated when the fleet leaders reach 75% of the design service objective. At this time the fleet exceeding 50% of the design objectives is included in a so-called candidate fleet. These principles were

| Structural configuration | Threshold based on initial flaws | | Threshold based on fatigue | |
|------------------------------|----------------------------------|---|----------------------------|---|
| | Threshold Design goal | Equivalent fatigue cracking probability | Threshold Design goal | Equivalent fatigue cracking probability |
| Wing rear spar lower chord | 0.3 | 1/1,000 | 0.50 to 0.75 | $\frac{1}{250}$ to $\frac{1}{50}$ |
| Empennage jackscrew support | 0.6 | 1/150 | | |
| Fuselage crown skin stringer | 0.4 | 1/500 | | |
| Lap splice | 0.38 | 1/900 | | |

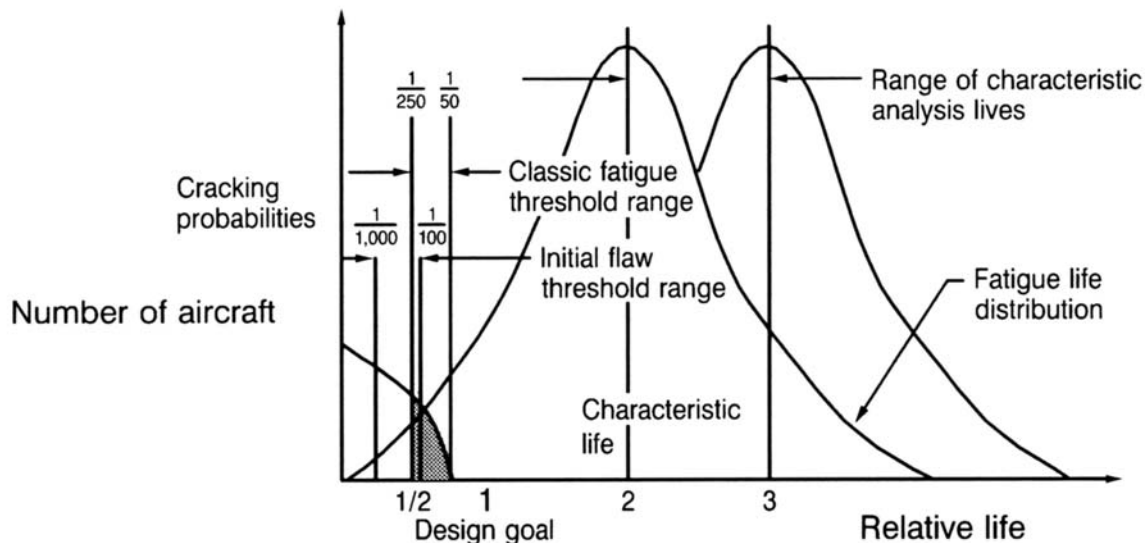
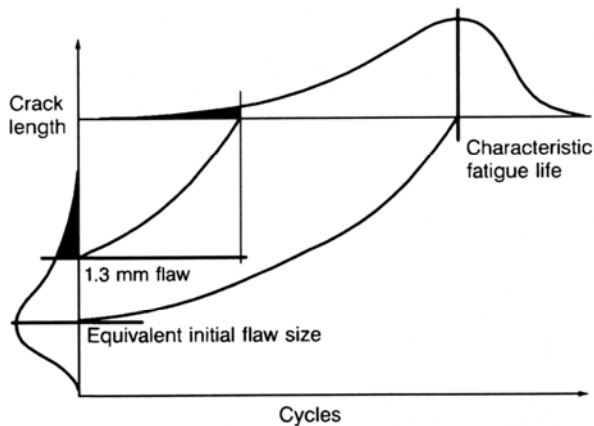

Figure 34. Threshold Examples Based on Classic Fatigue and Initial Flaw Concepts

initially developed more than ten years ago for the first generation of supplemental inspection programs. The rate of findings of previously unknown cracking does not support an often advocated abandoning of this approach in favor of initial flaw growth periods to critical factored by two. A couple of examples in Figure 34 shows the comparable thresholds by either method. While some provisions exist to adjust the initial flaw for inherent manufacturing quality and life enhancements, the end product of such assessments offer little advantage over service/test demonstrated fatigue initiation data. Figure 35 shows samples of initial flaws simulating typical structural fatigue details. A rogue flaw obviously implies different probabilities of occurrence depending on configuration and load transfer parameters.



| Structural configuration | | Equivalent initial flaw size, mm | Probability of flaws exceeding 1.3 mm, % |
|--------------------------|------------------------|----------------------------------|--|
| Wing spanwise splice | Clearance fit | 0.5 | 6.0 |
| | Interference fit | 0.05 | 0.003 |
| Fuselage lap splice | Standard driven rivets | 0.25 | 8.5 |
| | Overdriven rivets | 0.15 | 0.04 |

Figure 35. Equivalent Initial Flaws for Various Fatigue Design Details

Fleet Sampling Options

The order of occurrence of usage dependent fatigue damage is random in a fleet of airplanes. Airplanes with the highest number of flights, however, are most likely to experience the earliest damage, and supplemental inspections on fleet leader airplanes give the greatest benefits for damage detection in the fleet. The selection of candidate airplanes is described below.

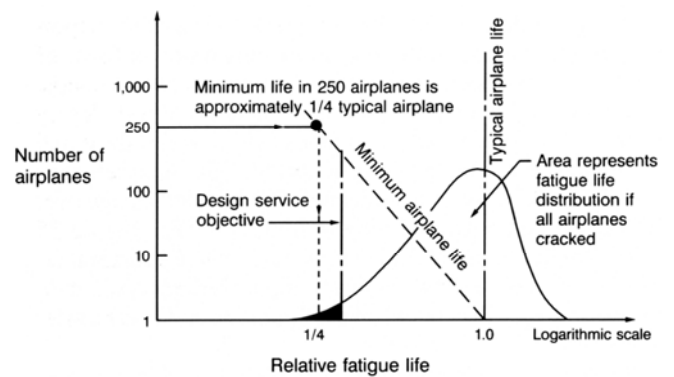

Figure 36. Variation of Minimum Life With Fleet Size

The fatigue life of damage tolerant structure corresponds to the accumulated flight cycles for fatigue damage to initiate and grow to detectable size, Figure 36. The characteristic life, β , exceeds the economic design life objective by several factors. The Weibull distribution can be used to estimate the minimum life for a given number of airplanes for an assumed characteristic (average) life. This minimum life decreases as the number of airplanes increases. The relationship between minimum life and characteristic life is represented by a straight line in logarithmic coordinates. The minimum life is 25% of the characteristic life for 250 airplanes with typical aluminum variability.

The order of cracking is random and unique for each fleet. Airplanes with the highest number of flight cycles are most likely to crack first. The earliest cracking may occur when the fleet utilization curve meets the line defining minimum (first crack) life, Figure 37. Since the fleet size, production rate, and utilization are different for each fleet, a varying initial crack threshold results. The most likely group of airplanes to experience the initial cracking are those with more flight cycles than defined by this meeting point. These airplanes are suitable candidates for an aging fleet inspection program.

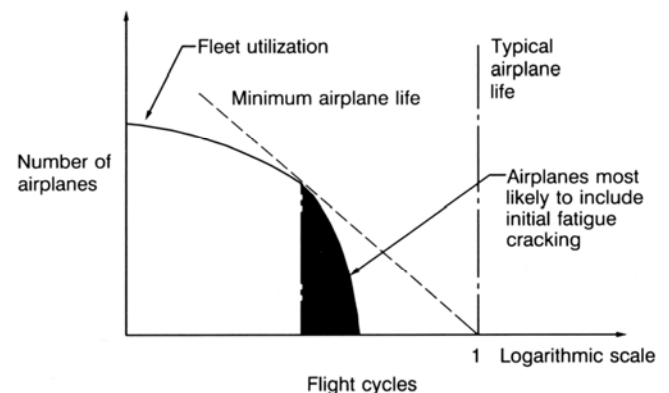

Figure 37. Fleet Cracking Order Based on Fatigue Life Distribution

Based on typical Boeing fleet distributions, the candidate airplanes most likely to experience initial fatigue cracking are those exceeding 50% of the fatigue design service objective when a normal service airplane reaches 75% of the

same life goal, Figure 38. Because the relationship between typical and minimum fatigue life is constant, the candidate fleet will not change unless there are significant changes in airplane distribution, composition, or utilization. The candidate population is therefore not changed as additional airplanes reach half of the design objective. This provides for a fleet leader population that moves with the total fleet and eliminates life thresholds that usually result in an increasing number of airplanes subject to supplemental inspection requirements.

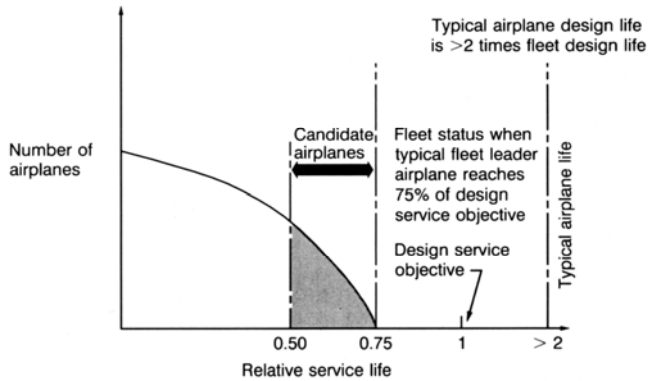

Figure 38 Supplemental Inspection Candidate Airplane Criteria

The candidate airplanes subject to the supplemental inspection requirements are identified by their serial numbers. Not all candidate airplanes need to be inspected because existing maintenance programs in many cases require only modification and/or supplemental inspections to meet the required damage detection reliability. Because damage is assumed to have occurred in the candidate fleet, P_1 is unity if all candidate airplanes are inspected. The probability of inspecting an airplane with damage is highest if fleet leaders are inspected. Fleet leader programs in the past usually have been selected with a fixed number of high time airplanes. Extension of this concept may often be practical because a few operators operate a large number of high time airplanes. Fleet sampling option tradeoffs must therefore be considered.

Fleet leader sampling involves repeat inspections at regular intervals of a specified number of airplanes with the highest number of flight cycles in each operator's fleet. Rotational sampling involves inspections of a fraction of an operator's candidate fleet with a specified interval until all candidate airplanes are inspected at least once.

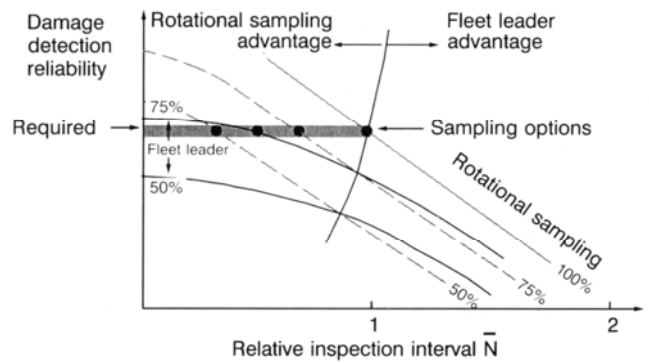

Figure 39. Fleet Sampling Options

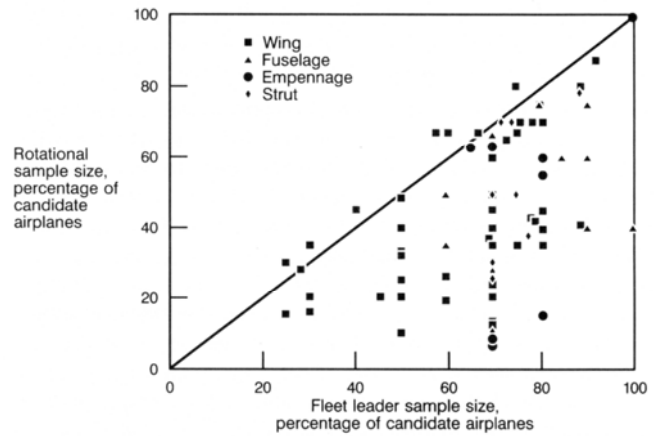

Figure 40. Fleet Sampling Efficiency Comparisons

Because the probability of inspecting a cracked airplane, P_1 , is less than one for fleet leader inspections, the attainable damage detection reliability is limited as the probability of detection P_3 is approaching unity for short inspection intervals, Figure 39. Evaluations of typical maintenance programs show very few cases where fleet leader sampling shows any benefits versus rotational sampling, Figure 40. These results are based on comparisons of the two sampling methods at a typical maintenance interval and required incremental detection reliability considerations. The fleet leader sampling option was therefore eliminated from the supplemental inspection program since rotational sampling provides for greater operator scheduling flexibility.

Multiple Cracking Considerations. Typical inspection threshold determinations previously reviewed address local cracking in one or more airplanes. Continued operations of aging jet transports towards and beyond original design service objectives have prompted extensive industry actions to address widespread fatigue damage concerns. The simultaneous presence of Multiple Site Damage (MSD) or Multiple Element Damage (MED) offers additional challenges for proper selection of inspection thresholds.

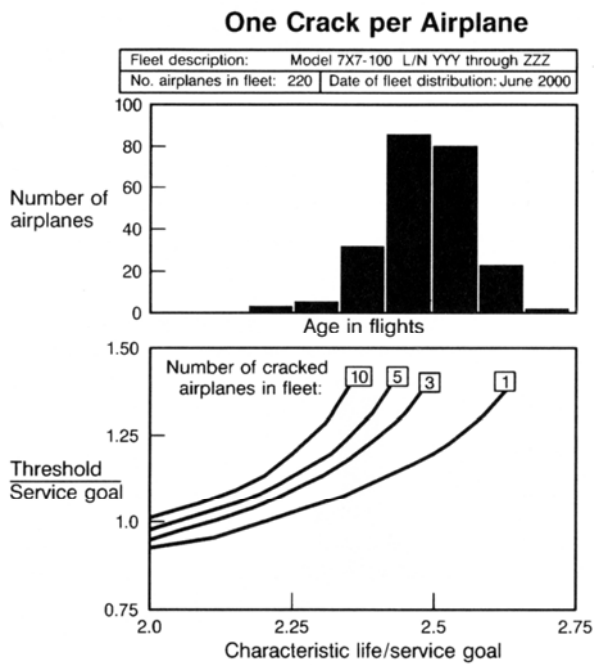

Figure 41. Fleet Service Cracking Estimate Example—One Crack per Airplane

Fatigue life distributions coupled with fleet usage characteristics can be applied to address inspection threshold selections. Figure 41 shows the inspection thresholds for different numbers of projected airplanes with single cracks in a major component. Figure 42 shows threshold estimates for varying numbers of cracks per airplane as well as number of assumed airplanes with cracks in the fleet. These projections can be determined for different calendar years to supply the engineer with estimates when structural and/or other corrective actions need to be implemented, Figures 43 and 44.

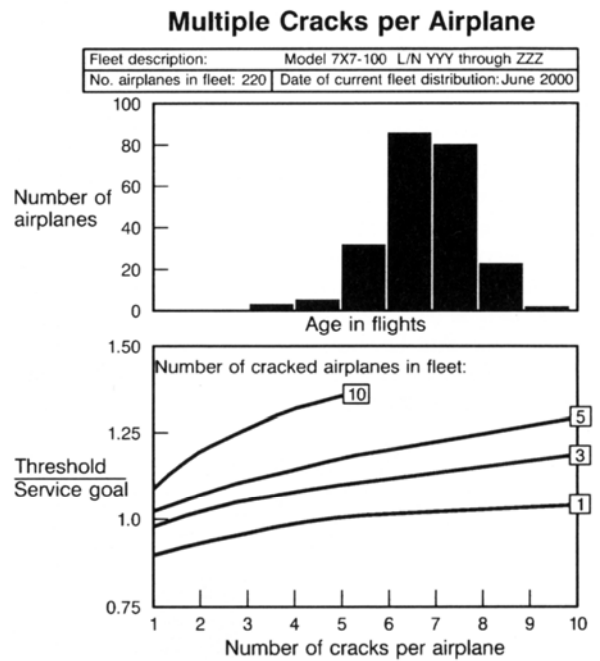

Figure 42. Fleet Service Cracking Estimate Example—Multiple Cracks per Airplane

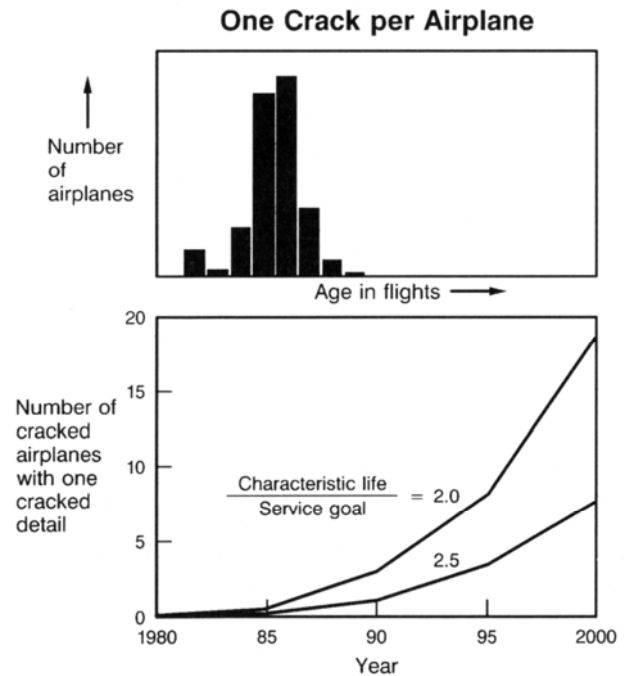

Figure 43. Predicted Fleet Cracking Example—One Crack per Airplane

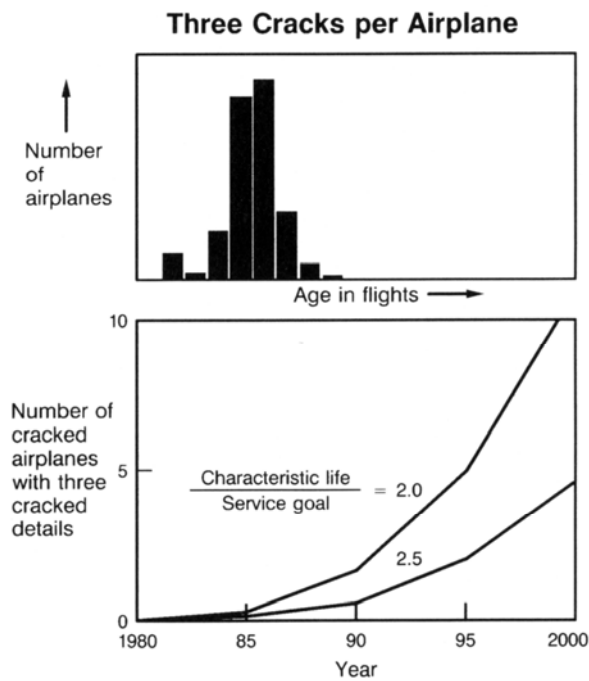

Figure 44. Predicted Fleet Cracking Example — Three Cracks per Airplane

Inspection Intervals

Structural inspection program planning involves fracture mechanics evaluations of crack growth and residual strength characteristics coupled to a damage detection assessment. Residual strength and fatigue crack growth evaluations are combined with service based crack detection data to produce detection reliability representing multiple type and intervals of inspections in a fleet of airplanes subjected to exploratory inspections. Such data give operators freedom to adjust quantitatively their maintenance program in any manner that is desired as long as the required reliability of damage detection is preserved.

Traditional damage tolerance evaluations often concentrate predominantly on the fracture mechanics aspects and the inspection intervals are often simply chosen to reflect half of the damage growth period from detectable to critical damage sizes. Such evaluations often fail to reflect the combined benefits of visual inspections performed during normal maintenance programs focused primarily on corrosion and accidental damage sources. The value of cumulative contributions of multiple inspections in a fleet of airplanes must also be recognized by accounting for such additional detection opportunities before the most critical change in one airplane reaches limit load damage containment capability. Several of these damage detection considerations are discussed in the following sections.

Structural Characteristics. Airplane structure can be categorized for the purpose of determining safety analysis requirements, Figure 2. Any structural detail, element or assembly is classified as a Structurally Significant Item (SSI) if its failure reduces airplane residual strength below

regulatory levels or results in an unacceptable loss of function. Most SSIs require damage tolerance evaluations comprising residual strength for Category 2 structure and all three elements of damage tolerance for Category 3 structure.

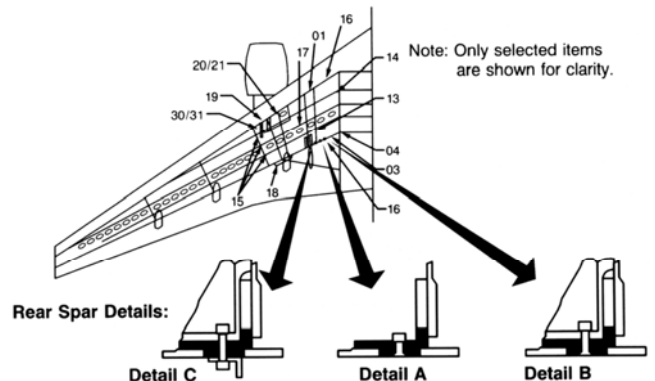

Figure 45. Structurally Significant Item Examples for Wingbox

The structure of each airplane model undergoes a thorough examination to ascertain the functions of its components and, as necessary, to classify those components. For the new models, this evaluation is performed using the FAA approved guidelines of MSG3. These evaluations are conducted, in support of a Structures Working Group established jointly by Boeing and operators, to develop the structural maintenance program. As a consequence of examinations, some 80 to 100 SSIs can typically be identified on each airplane model. As an example, 33 SSIs for a typical outer wingbox are shown in Figures 45 and 46. Each SSI may cover a broad expanse of structure. For example, the entire wing rear spar lower chord and skin may represent a single SSI. In consequence, the SSI may be divided into a number of details based on access, inspectability, stress level, material, and detail design differences. The example in Figure 45 shows three details in a single rib bay. Detail A shows typical rear spar structure; detail B shows the rear spar at a rib where internal inspection is restricted; detail C shows the rear spar at a rib where a main landing gear trunnion support fitting additionally restricts external inspection. Within each detail, the inspectable initial damage is assumed to occur in the most difficult location from the viewpoint of inspectability, regardless of the relative fatigue life of the component. In the selected lower chord example, crack growth calculations are performed for cracks in the chord itself, in the skin, and as appropriate in the web. These cracks grow interactively, with each influencing to some degree the behavior of the others. Separate analyses may occasionally be required to accommodate crack growth data necessary to evaluate the effectiveness of selected nondestructive testing techniques. Thus, in summary, a formal damage tolerance evaluation of an airplane structure may involve crack growth and probability of detection determination at several hundred details with two to three times as many crack growth curves to represent adjacent structural elements. Some 150 to 250 of these, representing the most critical, are published in

formal certification documentation. Each crack growth analysis must take into account the unique aspects of load spectrum, stress level, material, geometry and interaction between adjacent structural elements.

| SSI No. | Title |
|---------|---|
| 01 | Front spar - typical details |
| 02 | Front spar - nacelle fitting installation |
| 03 | Rear spar - typical details |
| 04 | Rear spar (from SOB to rib 1) |
| 05 | Rear spar - forward trunnion fitting installation |
| 06 | Rear spar - MLGB outboard support fitting installation |
| 07 | Rear spar - flap support fitting installation (ribs 17 and 24) |
| 08 | Non-shear-tied ribs (except details of 09) - typical details |
| 09 | Ribs Nos. 1 and 2 - internal fittings and adjacent web |
| 10 | Shear-tied ribs (Nos. 4, 7, 8, 10, 17, 24) (except details of 11) - typical details |
| 11 | Shear-tied ribs in dry bay (No. 7 and 8) |
| 12 | Outboard wing lower surface - typical stringer |
| 13 | Outboard wing lower surface - rib shear tie and support fittings |
| 14 | Outboard wing lower surface - drain installation |
| 15 | Outboard wing lower surface - spanwise splice |
| 16 | Spar chords to lower wing skin attachment |
| 17 | Access hole - lower wing surface |
| 18 | MLGB outboard support fitting to lower surface attachment |
| 19 | Nacelle fitting attachment to lower wing surface |
| 20 | Dry bay typical skin/stringer construction |
| 21 | Dry bay barrier installation |
| 22 | Dry bay flame arrester installation |
| 23 | Typical skin/stringer and rib shear tie attachment upper surface |
| 24 | Upper wing skin spanwise splice and spar chord attachment |
| 25 | MLGB outboard support fitting and trunnion to upper skin attachment |
| 26 | Upper surface fuel filler cap |
| 27 | Nacelle strut to upper skin attachment |
| 28 | Nacelle support side load backup fitting |
| 29 | Rear spar pitch load fitting |
| 30 | Outboard side load fitting |
| 31 | Inboard side load fitting |
| 32 | Nacelle side brace support fitting |
| 33 | Front spar pitch load fitting |

Figure 46. Structurally Significant Item Examples for Wingbox

Damage Detection Considerations

The inspectable crack length at the time of inspection may be significantly different from the total crack length obtained by fracture mechanics calculations depending on several factors such as location of the cracks and direction and method of inspection. For example, consider the inspectable crack length for the detail shown in Figure 47. If inspected visually, the crack would be detectable past A or B, depending on the side of the detail inspected. The crack must grow far enough that the tip is beyond any obstruction, in this case the sheet and sealant on the top and the sealant over the fastener on the bottom. The inspectable crack length is zero when the tip clears the obstruction edge (locations A and B) even though the actual length is significantly greater. For inspections from the bottom of the detail after the crack tip reaches C, the inspectable length will not increase, because the crack past that point will not be visible.

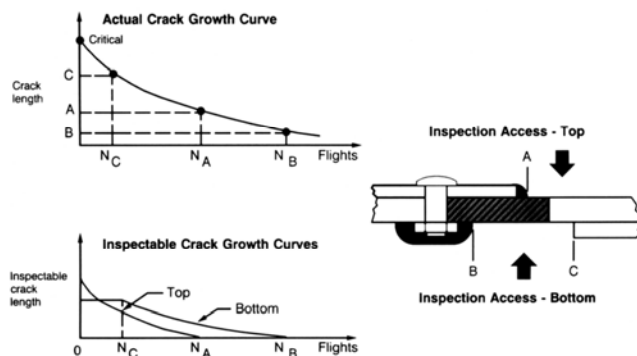

Figure 47. Inspectable Crack Length Considerations

Design objectives for damage tolerant structures include emphasis on accessibility and inspectability. The operator desires flexible maintenance programs which allow inspection intervals for fatigue damage inspections which are compatible with typical intervals used for corrosion and accidental damage inspections.

Changes in stress levels of about 15% can easily change the damage detection period by a factor of two. Improved material properties can also influence the damage detection period by similar factors. Lack of accessibility for visual inspection can be alleviated by deploying non-destructive inspection techniques. Multiple site damage scenarios often lead to rapid linkup of cracks in combination with reduced residual strength capability, i.e., smaller critical crack lengths.

The commonly used practice to set inspection intervals to half the damage detection period fails to provide a quantitative damage detection reliability. Figures 48 through 52 show cumulative damage detection probabilities under different combinations of damage growth characteristics and inspection options compared to results for inspection intervals equal to half the damage detection periods. It is apparent that required detection probabilities result in quite different inspection intervals compared to simple factoring of the detection period by two.

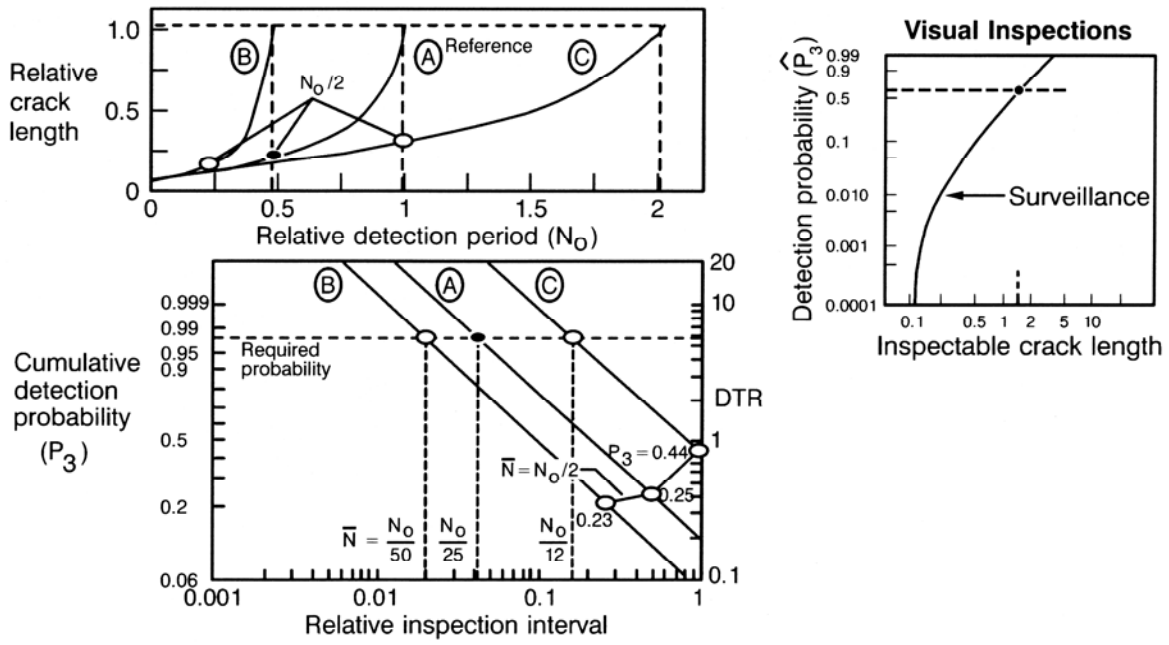

Figure 48. Cumulative Detection Probability — Detection Period Variation

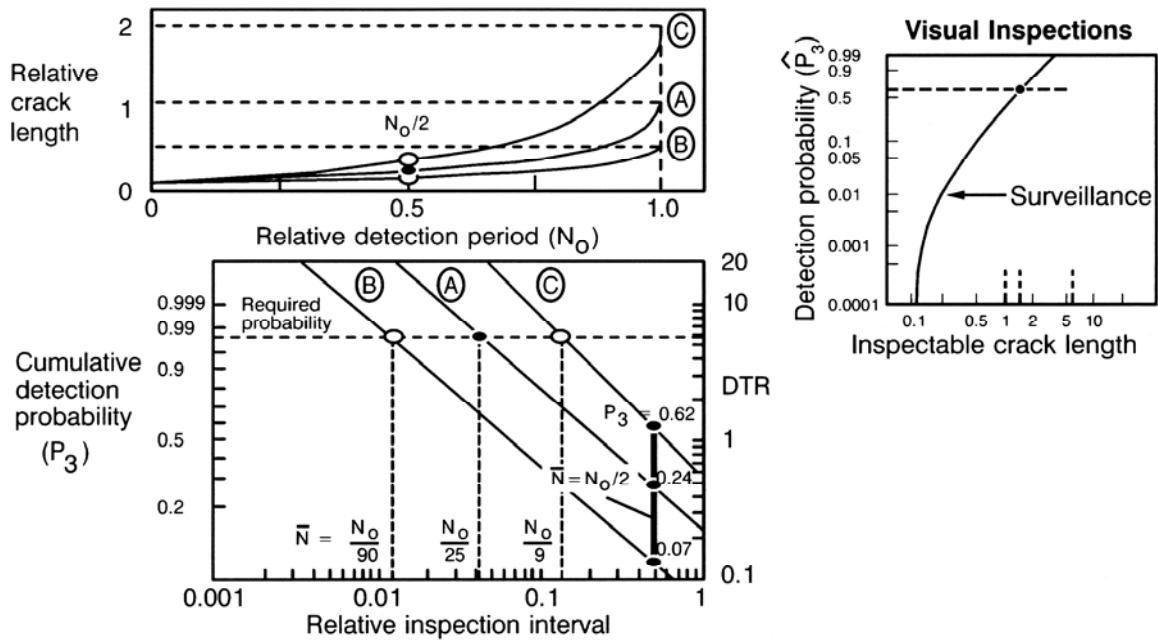

Figure 49. Cumulative Detection Probability — Critical Crack Length Variation

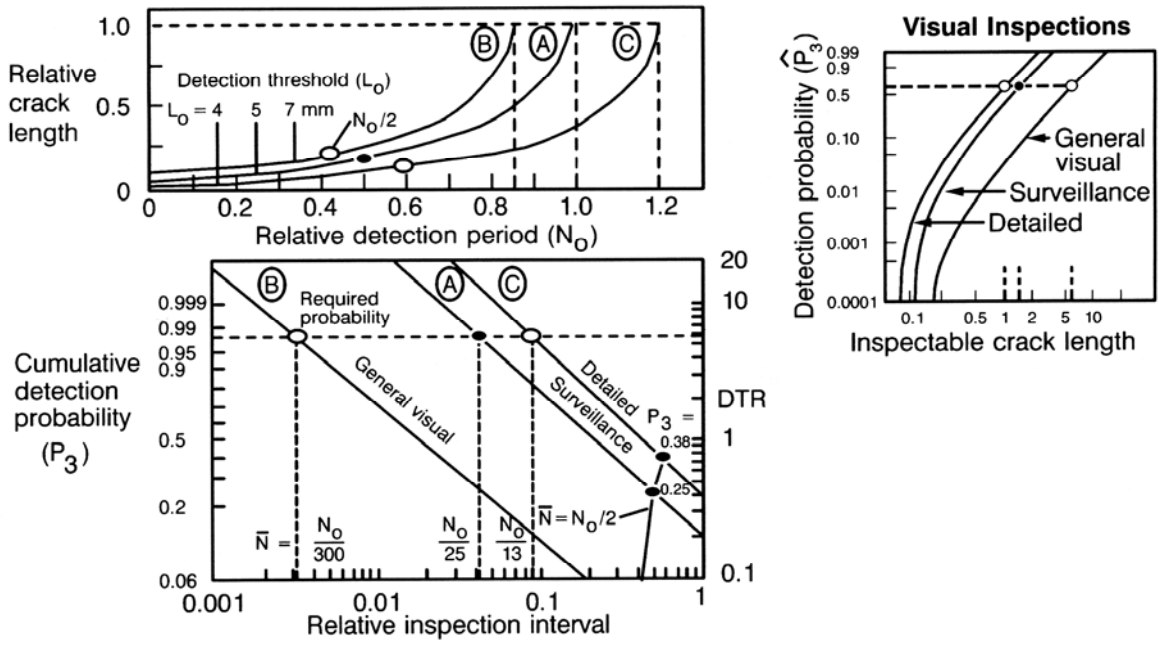

Figure 50. Cumulative Detection Probability — Inspection Type/Detection Threshold Variation

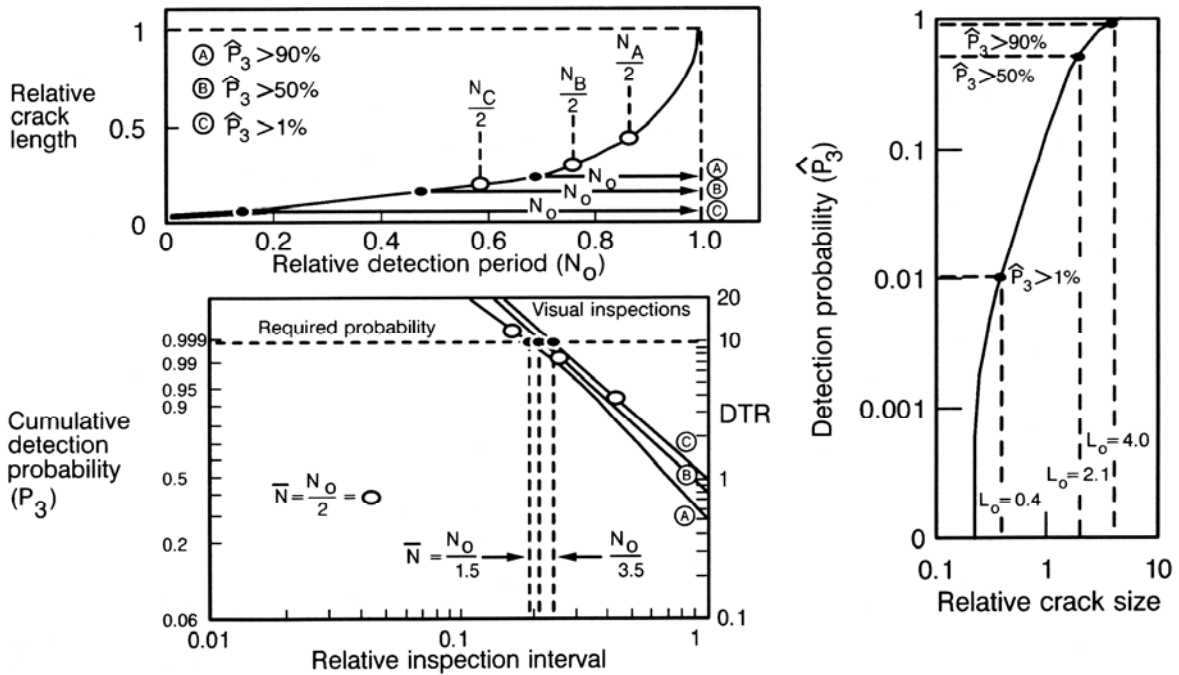

Figure 51. Cumulative Detection Probability — Detection Threshold Probability Variation

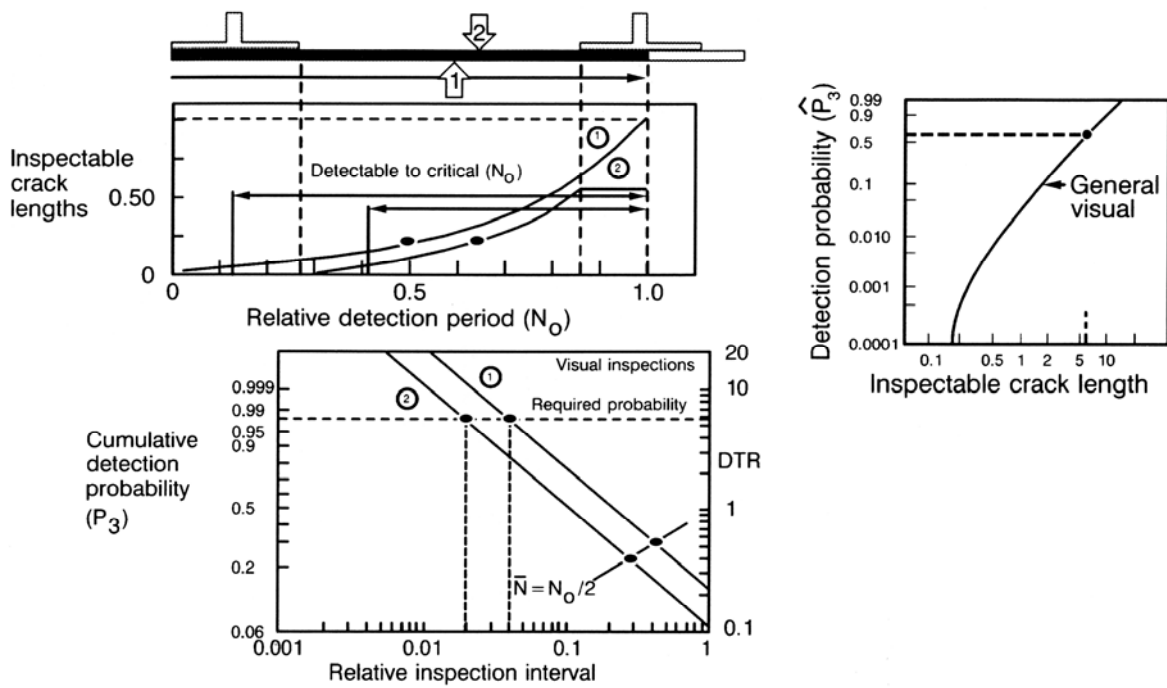

Figure 52 Cumulative Detection Probability — Inspection Direction Variation

Damage detection requirements can often be met by a combination of visual and non-destructive inspections. Figure 21 shows a simple example of visual external inspections and/or external NDI inspections. Figure 53 shows the cumulative probabilities of detection for different combinations of inspections. It should again be noted that simple factoring of the visual or NDI detection periods by two gives quite different detection reliabilities.

Visual inspections can often be performed from different directions and the cumulative detection reliability must be derived accordingly. Figure 54 shows a wing center section rear spar example for different cracking patterns (lead crack assumptions). Actual and inspectable crack growth curves for directions 1, 2 and 3 are shown in Figure 55 for these three cracking patterns. Corresponding cumulative detection probabilities for different inspection options are shown in Figure 56. An example maintenance program providing sufficient detection probabilities is shown in Figure 57.

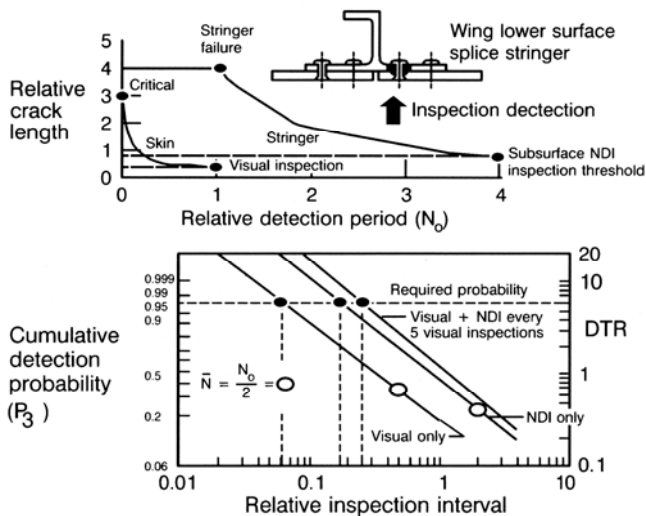

Figure 53. Cumulative Detection Probability — Inspection Method Variation

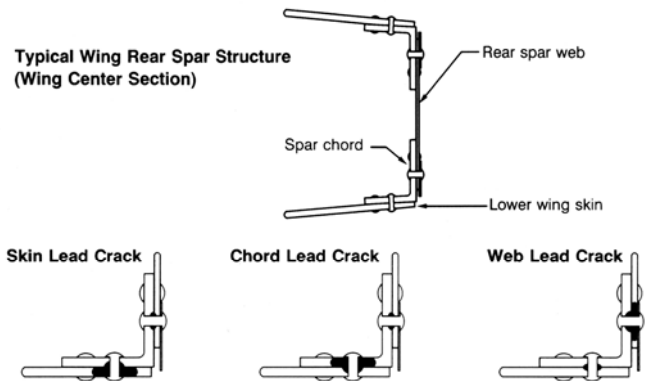

Figure 54. Wing Spar Chord Cracking Pattern Examples

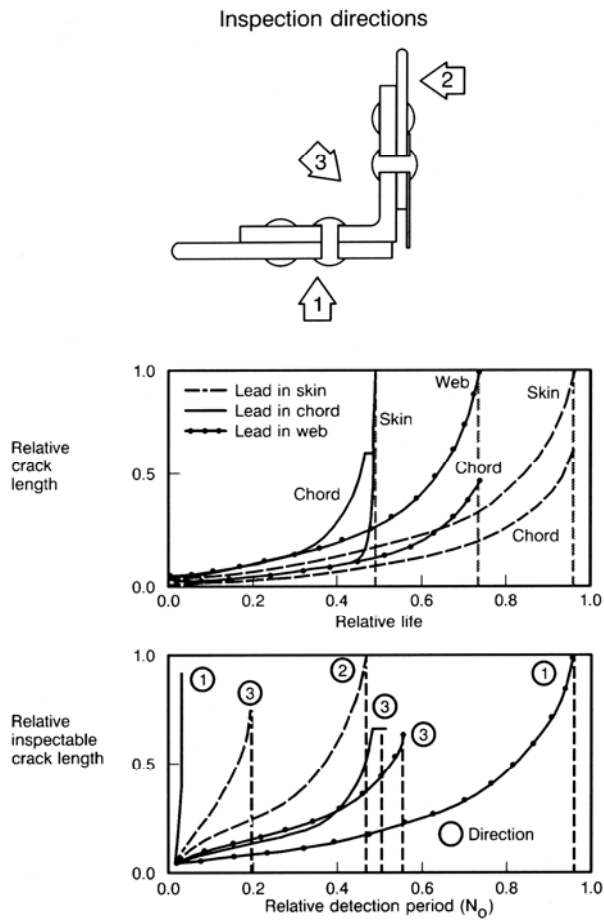

Figure 55. Spar Chord Crack Growth Curve Examples — Wing Center Section

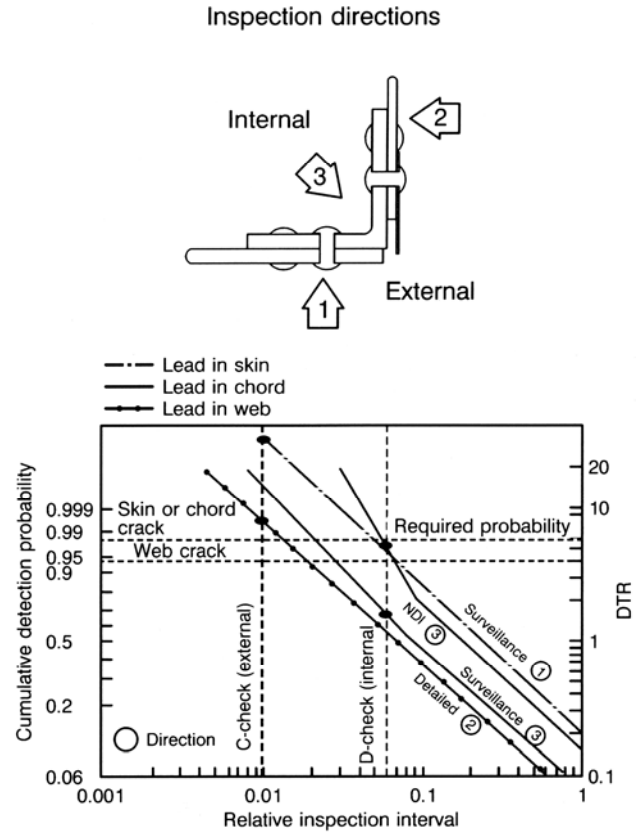

Figure 57. Cumulative Detection Probability — Cracking Pattern/Inspection Direction Combinations

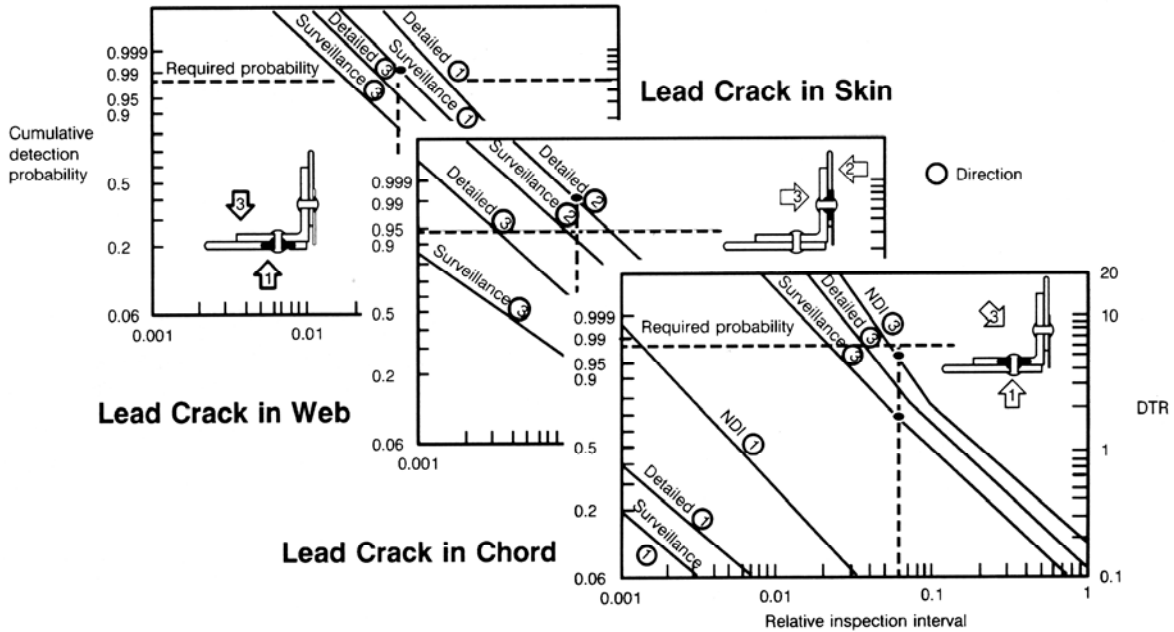

Figure 56. Cumulative Detection Probability — Cracking Pattern Variation

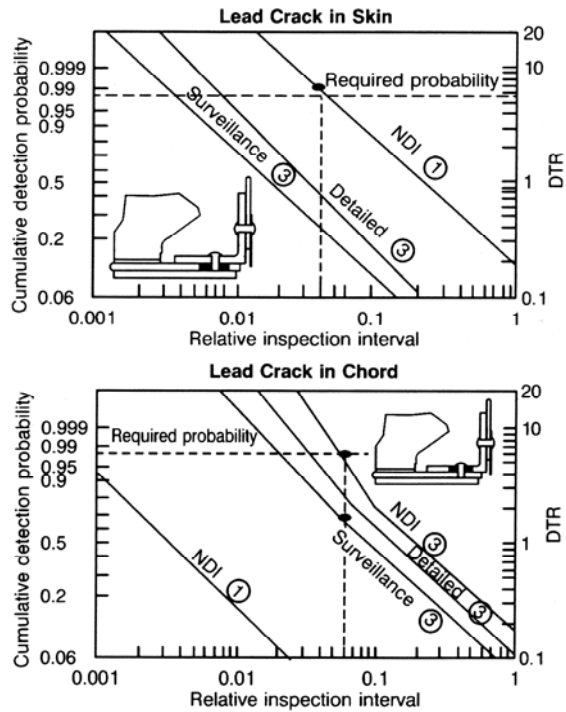
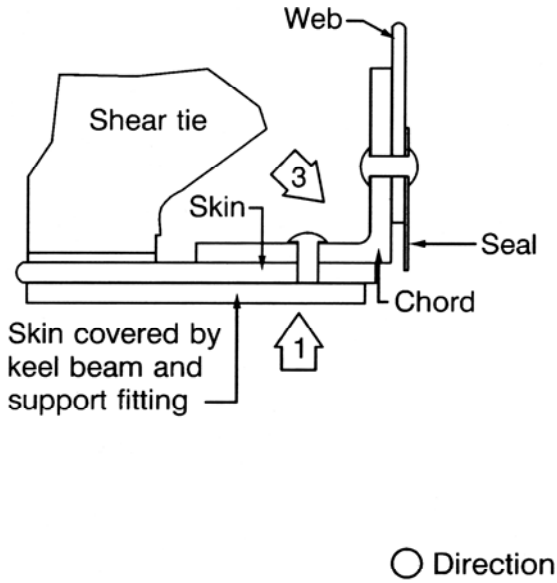

Figure 58. Cumulative Detection Probability Locally Hidden Skin Details

Figure 58 shows that the skin is covered by the keel beam at some locations which restricts external inspections. Such considerations must be made in the damage detection assessments to ensure that proper inspection intervals are selected. Web cracking is hidden by stiffeners as shown in Figure 59. NDI is typically required for such hidden details.

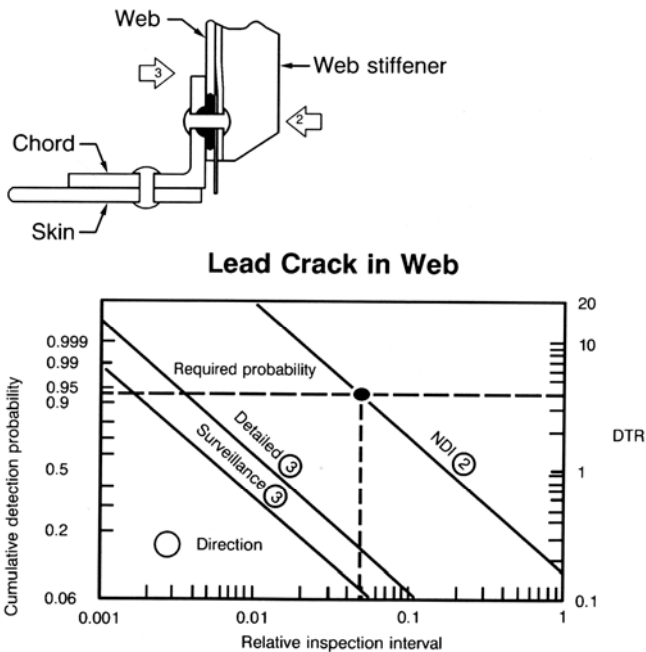

Figure 59. Cumulative Detection Probability Locally Hidden Web Details

Multiple Inspections

Experience has shown that when damage is detected in the fleet, further inspections generally reveal additional damage in the same detail on other airplanes and/or on a similar detail at another location. Additional damage in the fleet increases the probability of detecting at least one crack. The number of flights between occurrences in the fleet of fatigue damage to the same detail, ΔN can be derived from actual fleet cracking statistics or from fleet usage and fatigue-life distribution, Figure 60. If the first damage is detectable at N_1 flights, the second damage will reach the same level of detectability at $N_1 + \Delta N$, and the third at $N_1 + 2\Delta N$, Figure 61.

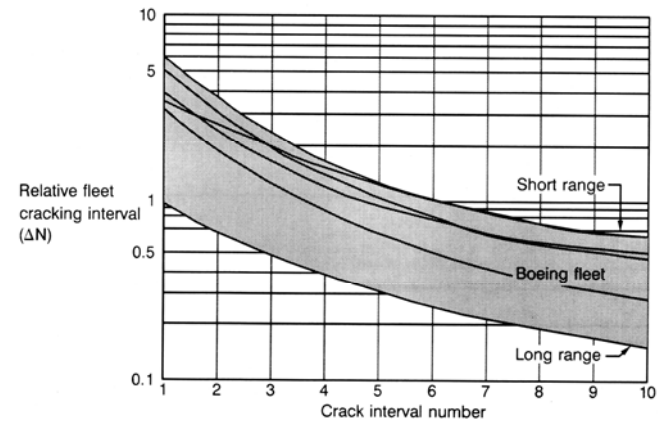

Figure 60. Fleet Cracking Variation — ΔN

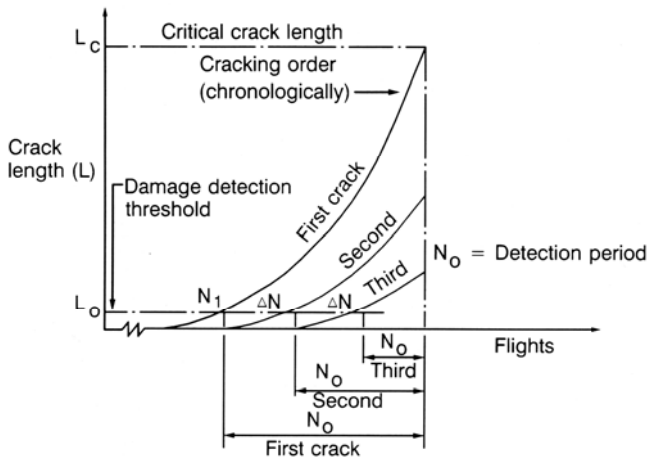

Figure 61. Multiple Cracking in the Fleet

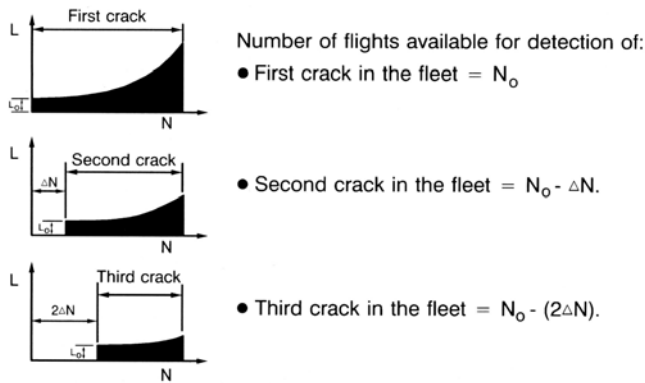

Figure 62. Multiple Fleet Cracking Contributions to Damage Detection

Each successive crack occurring during the damage detection period N_o , for the first crack, has a reduced interval for detection and a shorter crack length, Figure 62. Taking this into consideration, the cumulative probability of detection can be determined for each crack using the same procedure. From this the probability of crack detection in the fleet, using a given inspection method and frequency, as shown below

$$P_3 = 1 - \prod_{i=1}^m \prod_{j=1}^n (1 - \hat{P}_{3ij})$$

where \hat{P}_{3ij} is the probability of detection during the i th inspection of the j th cracked airplane during the damage detection period N_o ; m is the number of cracked airplanes; and n is the number of inspections performed on the j th cracked airplane.

For convenience an equivalent constant probability of detection for each inspection can be defined by:

$$\bar{P}_3 = 1 - (1 - \hat{P}_3) \bar{N}/N_o$$

Considering all levels of inspection in the fleet (A, B, C and D), the cumulative probability of damage detection is given by:

$$P_D = 1 - \pi (1 - P_{di})$$

$$\text{where } P_d = P_1 \cdot P_2 \cdot P_3$$

$i =$ applicable inspections

Values of P_D such as 0.999 and 0.998 appear to be very close. If the probability of not detecting damage ($1 - P_D$) is considered, it can be seen that there is actually a 2-to-1 difference in these values. This provides a better comparison between P_D levels. To provide a direct qualitative measure of design and/or maintenance planning options, an equivalent number of 50/50 opportunities of detection is used to define a DTR discussed previously, Figure 24.

The relative contributions from fleet inspections in relation to the single airplane contribution must be considered to ensure that the total detection reliability is not achieved by long detection periods, N_o , and low individual airplane damage detection contributions, Figure 63. The total DTR for fleet inspection contributions is thus limited to twice the single airplane DTR contributions.

It should be noted that the contribution from these fleet inspections should only be accounted for in exploratory inspections. Known service problem inspections are focused on single airplane safety inspections and the benefits of additional cracking must not be included.

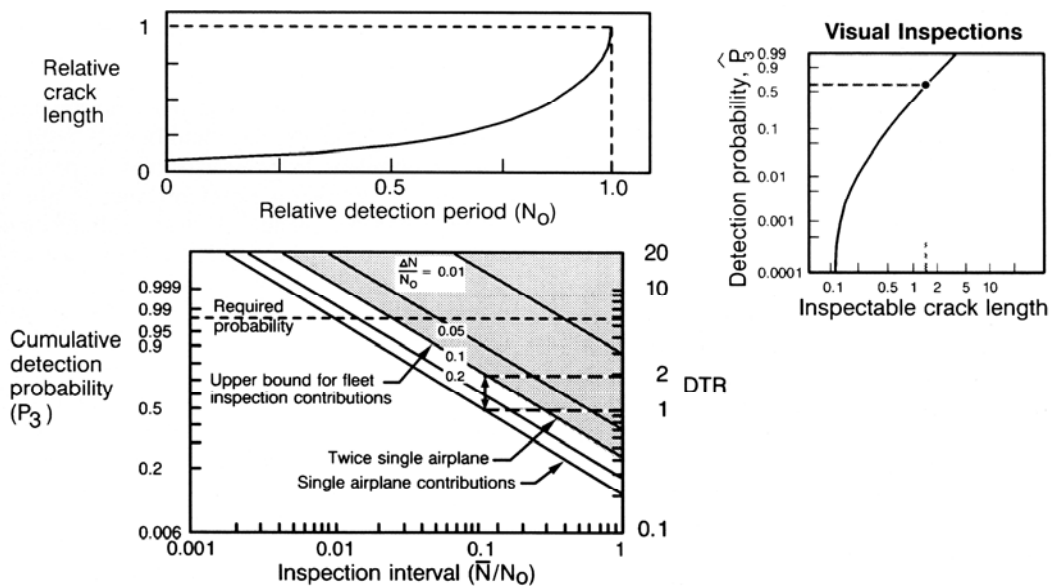

Figure 63. Cumulative Detection Probability — Fleet Inspection Detection Contributions

CONTINUING AIRWORTHINESS CHALLENGES

Continuing airworthiness concerns for aging jet transports has received attention over the last fifteen years. Supplemental structural inspection programs were developed in the late 1970s to address fatigue cracking detection in airplanes designed to the fail-safe principles. These evaluations were performed in accordance with updated damage tolerance regulations to reflect the state-of-the-art in residual strength and crack growth analyses based on fracture mechanics principles. Damage at multiple sites was also addressed in terms of dependent damage size distributions in relation to assumed lead cracks in different structural members. Structural audits were performed in the mid 1980s to ascertain whether these supplemental inspection programs addressed independent multiple site damage in similar structural details subjected to similar stresses. The safe decompression concepts were challenged in these reviews of different manufacturer damage tolerance philosophies but no major changes occurred.

Boeing initiated aging fleet surveys by engineering teams in 1986 to gain a better understanding of the condition of structures and systems and to observe the effectiveness of corrosion prevention features and other corrosion control actions taken by the operators, Figure 64. Boeing like other manufacturers continually reviews reported service data and other firsthand information from customer airlines in order to promote safe and economic operation of the worldwide fleet. These surveys were primarily prompted by the projected upward trend in airplane age towards and beyond original design service objectives.

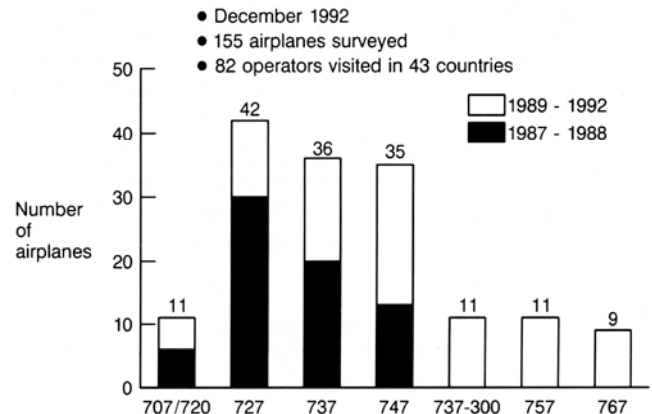

Figure 64. Boeing Fleet Surveys

The initial Boeing fleet surveys showed that the majority of the airplanes were well maintained and in relative good condition. However there were a number of airplanes whose condition showed that finding corrosion discrepancies and repairing them was accepted practice and little or no attempt was made to apply any preventive measures. From the surveys and some similar incidents it became apparent that some airplanes were continually operating with significant structural corrosion and that this was on the increase as airplanes age. This in turn could significantly influence the fatigue cracking and damage tolerance capability of principal structural elements. Boeing formed a special Corrosion Task Force in 1988 and held meetings with airline maintenance executives as a result of these surveys.

Extensive industry actions were initiated in 1988 to address aging fleet airworthiness concerns prompted by the explosive decompression of a 737 over Hawaii. Model-specific Structures Working Groups have demonstrated a cooperative determination over the last five-year period to make the right things happen within and across models and throughout the industry. The achievements have been impressive in the accomplishing of results in five original

tasks chartered by the Airworthiness Assurance Task Force, now known as the Airworthiness Assurance Working Group, Figure 65.

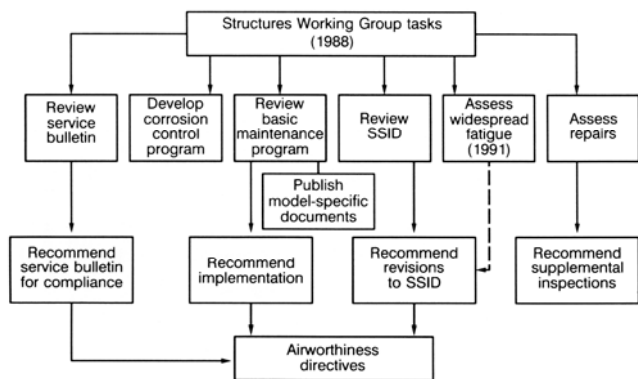

Figure 65. Industry Aging Fleet Initiatives

While multiple site concerns were addressed in the updates of Supplemental Structural Inspection Programs (SSIP), new rulemaking proposals emerged to require fatigue testing of older airplanes in an attempt to reduce exposure to unknown fatigue problems and to identify significant widespread fatigue damage (WFD) before it occurred in the commercial fleet. Considerable activities were undertaken by AAWG to address WFD concerns and recommended alternate means of ensuring the fleet is free from widespread cracking. These activities have resulted in comprehensive reports and formation of industry/operator/regulatory agency teams to develop recommendations for audits of structures with regard to WFD and recommended inspection/modification programs.

This section reviews some of these six industry activities with emphasis on damage detection considerations.

Service Bulletin Reviews

Continuing airworthiness of jet transport structures designed to the fail-safe principles have traditionally been ensured by inspection programs. In the event of known, specific fatigue cracking and/or corrosion problems that if not detected and repaired, had the potential to cause a significant degradation in airworthiness, the normal practice in the past was to introduce a service bulletin, Figure 66. These bulletins defined inspection procedures (method, threshold and interval) which were designed to ensure with high (but undefined) degree of probability that the structural damage would be detected (and be repaired) before significant degradation in structural airworthiness occurred. Frequently these service bulletins would also specify modifications/rework procedures that would eliminate the cause of the cracking problems and provide an alternative to repetitive inspections as a means of ensuring continued structural integrity. The inspection parts of the service bulletins were sometimes mandated by means of Airworthiness Directives.

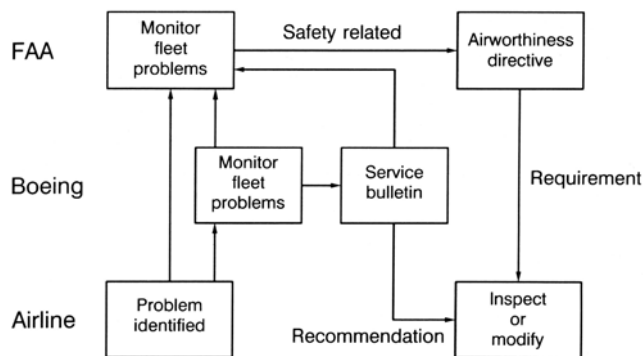

Figure 66. In-Service Problem Actions

The net result of this process was to carry out inspections of all affected airplanes until damage was detected and then to perform the repair. Thus, continuing structural airworthiness was totally dependent on repetitive inspections. Aging airplane concerns prompted reassessment of the viability of indefinite repetitive inspections.

As airplanes age, the incidence of fatigue increases and corrosion becomes more widespread. Problems are often addressed in isolation during the early service use of airplanes. With age, two or more problems in an area may degrade airplane structural fail-safe capability. This increases the need to incorporate preventive modifications in areas within known problems. The criteria for selection of service bulletins for high-time airplane modification are based on considerations such as safety problem potential, high probability of occurrence, and difficulty of inspection.

A candidate list of service bulletins was established by Boeing as a baseline after a thorough review of those applicable to long-term operation. These service bulletins were reviewed by the respective working groups for recommended terminating actions. The thresholds for these mandated repairs and modifications were typically selected as the design objective in flight cycles for fatigue related problems. Earlier calendar time thresholds were necessary for items driven by corrosion or stress corrosion considerations. The resulting selection of service bulletins for which mandatory modifications were recommended was guided by a rating system developed by working group members to reflect their own experience.

Aging fleet service bulletin summary documents were released in 1989 for each model formalizing Structures Working Group (SWG) recommendations for mandatory modifications or inspections. The details of each modification or inspection and the affected airplanes are described in applicable service bulletins. The summary documents were used as a record of SWG recommendations and as a reference for the airworthiness directive actions. Airworthiness directives were issued in 1990 for incorporation of structural modifications listed in these documents upon reaching the thresholds specified or generally within four years after the effective date of the AD, whichever occurs later. Annual reviews are conducted to update the existing program and evaluate any new service

bulletins for possible modification actions. Several service bulletins have been updated with more specific inspection recommendations as an alternative to mandatory modifications.

It is important to note that cumulative service experience is incorporated in the design and reflected by less inspection/modification for later production units. In turn, these service experiences are incorporated in new models, often with orders of magnitude reduction in modification later efforts, Figure 67.

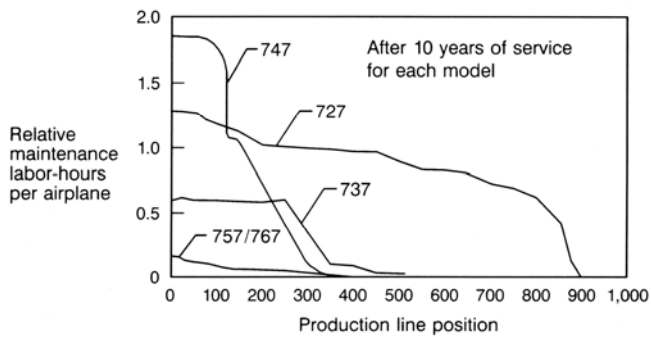

Figure 67. Comparison of Service Bulletin Labor Hours Related to Corrosion and Fatigue

The modifications are to a large extent focused on corrosion related problems. Figure 68 shows a typical example of stress corrosion prone 7079 aluminum fittings replaced by 7075-T73 fittings on the 727 horizontal stabilizer center section front spar. Approximately 20% of mandated modifications address fatigue problems. Figure 69 shows a typical fatigue related modification of the EF window post on a 727 which has exhibited in-service fatigue problems.

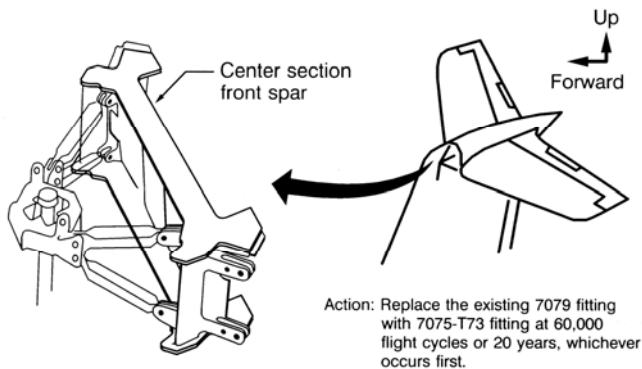

Figure 68. Mandatory Service Bulletin Modification Example for 727 Horizontal Stabilizer Front Spar Center Section With Stress Corrosion Problems

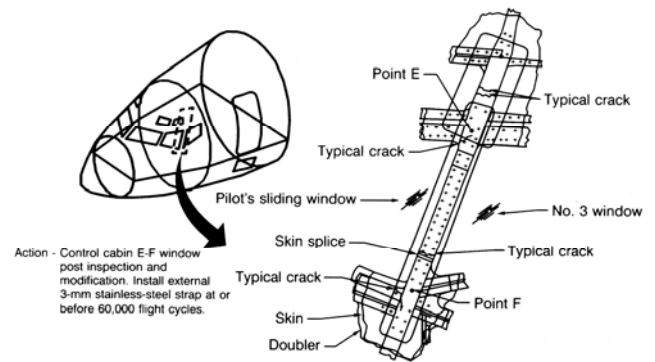

Figure 69. Mandatory Service Bulletin Modification Example for 727 Cab Window Post With Fatigue Problems

Corrosion Prevention and Control Programs

While corrosion has always been recognized as a major factor in airplane maintenance, each airline has addressed it differently according to its operating environment and perceived needs. Manufacturers have published corrosion prevention manuals and guidelines to assist the operators, but until now there have never been mandatory corrosion control programs.

In the late 1970s, when Boeing was developing fatigue related SSIDs, a basic assumption was made that the existing approved maintenance programs were controlling corrosion below levels that could affect airworthiness. Therefore, the resulting SSID programs centered around controlling the anticipated increasing fatigue damage that would occur as the fleet aged. However, the Boeing fleet surveys revealed that some operators did not utilize proven or effective corrosion prevention measures. In addition, some instances of very severe corrosion were observed reflecting improper or delayed prevention and repair actions.

It became apparent that without effective corrosion control programs, the frequency and severity of corrosion were increasing with airplane age and, as such, corrosion was more likely to be associated with other forms of damage such as fatigue cracking. This, if allowed to continue, could lead to an unacceptable degradation of structural integrity, and in an extreme instance, the loss of an airplane.

A typical damage growth pattern for fuselage skin and stringers is shown in Figure 70, left. The curves show the number of cycles remaining from a given detectable crack length until the combined growth reduces airplane residual strength to the design fail-safe level (critical). The period from when the fatigue damage is detectable (with some probability) until it reaches critical length is the safe damage detection period.

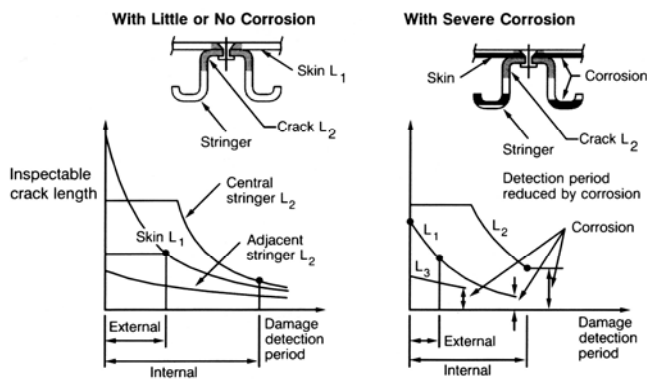

Figure 70. Corrosion Effects on Fatigue Damage Growth

Typically, Boeing damage tolerance assessments are based on the conservative assumption that if fatigue damage occurs, it will initiate in the structural component that is most difficult to inspect. In this case, it is the stringer (crack length L_2) which, because it is inside the fuselage, is inspected less frequently than the skin. At some point cracks are also assumed to occur in the skin (L_1) and the adjacent stringers (L_3). Crack growth rates and airplane residual strength are determined on the basis of typical operating loads, with stresses based on sound structure with little or no material loss due to corrosion.

If the structure is severely corroded, the damage detection period can be significantly reduced, Figure 70, right. Further, the random nature of corrosion would make it impossible to establish typical damage growth patterns, which would prevent the use of a fleet leader program for detecting initial fatigue damage in the fleet. To ensure continuing airworthiness, a highly conservative and very costly inspection program could be required. The alternative and more practical approach is to establish minimum standards for prevention or control of corrosion as a means of promoting continuing airworthiness.

The Boeing Corrosion Task Force reviewed all Boeing sources of information related to known corrosion problems. All problems relating to principal structural elements (PSE) were retained and segregated into selected general areas on the basis of having similar corrosion exposure characteristics and/or common inspection access requirements, Figure 71. Problems found to be significant in relation to continuing airworthiness were included in the program as specified tasks unless already covered by an existing airworthiness directive. It was recognized that corrosion growth rates varied widely, and it would be unduly conservative to establish a program based on the most severe operating environment. Therefore, the approach taken was to develop a baseline program that represented minimum requirements for typical operators. Individual operators who would experience significant corrosion after applying the baseline program must then modify or improve their program. The Boeing Corrosion Task Force developed a proposal for the baseline program based on existing recommendations, modified by current experience and knowledge gained by their review of available data.

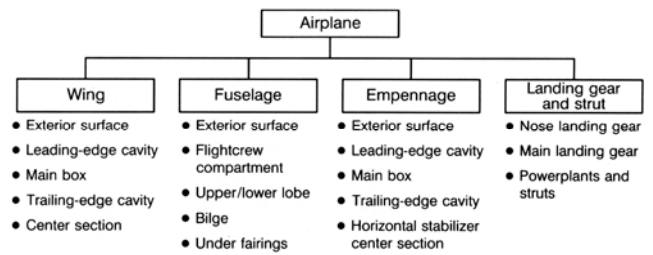

Figure 71. Corrosion Program Areas

The working groups have recognized the need for a universal baseline minimum corrosion control program for all airplanes to prevent corrosion from affecting airworthiness. Maximum commonality of approach within and between each manufacturer to ensure consistent and effective procedures throughout the world have been a key objective for the working groups. The program requirements apply to all airplanes that have reached or exceeded the specified implementation age threshold for each airplane area. The specific intervals and thresholds vary between models, but all programs follow the same basic philosophy and typically contain the following:

- External and internal inspections of all airplane structural areas are required at specified implementation times and repeat intervals. The program will require major opening up of the structure at these inspections. Figure 72 illustrates the required access to the 727 fuselage. It further details preventive measures including repair action and assurance that drain paths are clear, protective finishes are reapplied, and corrosion inhibiting compounds are applied.

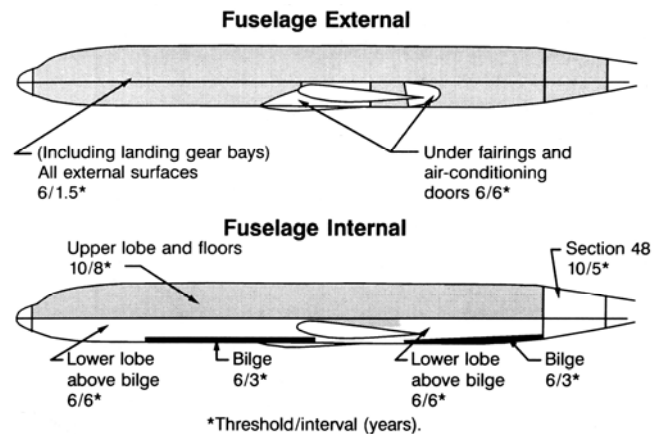

Figure 72. 727 Corrosion Control Program — Example

- Corrosion damage must be controlled between maintenance visits to acceptable minimums that will not adversely affect safety. The baseline program must be adjusted if necessary to achieve this standard.
- All cases of corrosion exceeding the minimum level must be reported, with particular emphasis on corrosion that raises an immediate safety concern. This will enable rapid response throughout the fleets to inspect and correct any potential problems.

- Intervals and implementation thresholds are based on area-and model-specific calendar times, Figure 73.
- The maximum period for implementing the program fleet wide in a given structural area is one repeat interval (not to exceed six years if over twenty years of age and a minimum rate equivalent to one airplane per year).

Many operators incorporated several corrosion program features in their heavy maintenance visits or when they accomplished the service bulletin modifications. Such pre-implementation provided valuable early feedback about the effectiveness of the program and further demonstrated the operators' responsiveness and commitment to the true spirit of safety. Boeing has also provided extensive training programs available to airline and airworthiness authorities personnel alike to ensure efficient corrosion prevention and control program implementation.

The corrosion control and prevention program provides structural access and inspections of internal structure and structure hidden by fairings in a disciplined and consistent manner. While many operators may already have covered these areas in existing maintenance programs, the net effect has been an increased awareness for the value of corrosion prevention and control (CPCP) programs. An additional benefit of the CPCP visual surveillance type inspections are realized in the benefits for fatigue damage inspections employed in the SSIPs. Figure 74 shows an example of the different zonal access inspections for CPCP in comparison with assumed typical maintenance programs for SSIP evaluations. The net benefit in normal maintenance damage detection considerations are shown in Figure 75.

| Structure | | Typical inspection intervals | | | |
|-----------|---------------------|------------------------------|--------------------------|-------------------------------|-------------------------|
| | | SSIP program, flights | CPCP, years | MPD/MRB, hours | |
| Wing | External | 1,750 °C | 5 | 1/2 at 16,000 16,000 spars | |
| | Leading edge | 1,750 °C | 5 | 16,000 | |
| | Trailing edge | 1,750 °C | 5 | 1/2 at 16,000 | |
| | Wing box | Outboard C/S | 14,000 "D" 14,000 "D" | 10 8 | 16,000 1/4 at 16,000 |
| Fuselage | External upper | 1,750 °C | 1.5 | 16,000 | |
| | External lower | 14,000 "D" | 1.5 | 16,000 | |
| | Lower internal | 14,000 "D" | 6 Bilge - 3 | 1/2 at 16,000 | |
| | Upper lobe internal | 14,000 "D" | 8 | 1/4 at 16,000 | |
| | Section 48 internal | 3,500 °C | 5 | 1/3 at 16,000 | |
| Empennage | External | 1,750 °C | 2 | 16,000 | |
| | Internal | Vert | 3,500 °C | 8 | 16,000 |
| | | Horiz | 3,500 °C | 8 | 1/3 at 16,000 |
| Strut | Strut | N/A | 2 | 1/3 at 16,000 | |

Note: Current 727 flight averages 1,550 flights; 2,000 hr per year ▷ Based on reference examples SSID.
 C-check = 2,000 flights; 15 months; 2,600 hr
 D-check = 14,000 flights; 9 years; 18,000 hr

Figure 74. Baseline Maintenance Program Example for 727 — Visual Surveillance of All Visible Structure

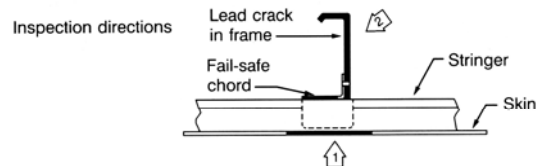

| Structures | Inspection method | Inspection intervals | | Detection probability (DTR/P ₃) | |
|--------------------------------------|-------------------|----------------------|-------------------------|---|------------|
| | | SSIP | CPCP | SSID | Corrosion |
| Skin external access (direction 1) | Detailed visual | 14,000 flights | | 1/0.5 | |
| | Surveillance | | 1.5 years/3,000 flights | | 9/0.998 |
| Frames internal access (direction 2) | Detailed visual | 30,000 flights | | 9/0.998 | |
| | Surveillance | | 3 years/6,000 flights | | >20/0.9999 |

Figure 75. Example of Mandatory Corrosion Inspection Contributions to Fatigue Damage Detection

| General area | | 707/720 | | 727 | | 737 | | 747 | |
|----------------------------|--|-----------------------|--------|-----------------------|--------|-----------------------|--------|-----------------------|--------------------|
| | | Threshold | Repeat | Threshold | Repeat | Threshold | Repeat | Threshold | Repeat |
| Wing | Outer - external | 10 | 4 | 10 | 5 | 8 | 4 | 10 | 2 |
| | Leading edge interior | 8 | 2/4 | 10 | 5 | 8 | 4 | 6 | 1.5 |
| | Outer - main box - interior | 10 | 8 | 10 | 10 | 10 | 10 | 20 | 10 |
| | Trailing edge interior | 8 | 2/4 | 10 | 5 | 8 | 2 | 10 | 2 |
| | Center section interior | 10 | 8 | 10 | 8 | 10 | 8 | 20 | 10 |
| Fuselage | External (including doors and landing gear bays) | 6 | 2 | 6 | 1.5 | 5/8 | 1.5/2 | 10 upper 5 lower | 5 upper 2 lower |
| | Flightcrew compartment | 10 | 8 | 10 | 8 | 10 | 8 | 15 | 8 |
| | Upper lobe interior | 8 | 8 | 10 | 8 | 8 | 8 | 15 | 8 |
| | Lower lobe interior (except bilge) | 6 | 6 | 6 | 6 | 6 | 5 | 6 | 6 |
| | Lower lobe - bilge | 6 | 3 | 6 | 3 | 6 | 2/4 | 6 | 4 |
| Section 48 interior | 10 | 5 | 10 | 5 | 8 | 4 | 10 | 5 | |
| V/H stabilizer | External surfaces | 10 | 2/4 | 10 | 2 | 10 | 2 | 10 | 5 |
| | Leading edges | 10 | 8 | 10 | 8 | 10 | 8 | 15 | 8 |
| | Main box interiors | 10 | 8 | 10 | 8 | 10 | 5 | 15 | 8 |
| | Trailing edges | 10 | 8 | 10 | 4 | 10 | 5 | 10 | 5 |
| | Center section | 10 | 5 | 10 | 5 | 8 | 4 | 10 | 8 |
| Center engine inlet duct | - | - | 10 | 8 | - | - | - | - | |
| Nose and main landing gear | | Landing gear overhaul | | Landing gear overhaul | | Landing gear overhaul | | Landing gear overhaul | |
| Powerplant and strut | | 4 | 2 | 5 | 2 | 5 | 5 | 7/15 | 3/15 |

Note: Some specific areas/items within the general areas have independent thresholds and repeat intervals.

Figure 73. Corrosion Inspection Thresholds and Inspection Interval Examples

There is general agreement in the airplane industry that corrosion prevention and control procedures are needed on all current in-production airplanes and for future generations of airplanes. In response to this, Boeing has worked in conjunction with customer airlines and regulatory authorities to develop CPCPs for 737-300/400/500, 747-400, 757 and 767 airplanes. A CPCP will also be included as part of the basic maintenance program for the new Boeing 777 jetliner scheduled for service introduction in 1995.

The basic philosophy and program content of the CPCPs for in-production airplanes is the same as that used for the “aging” airplane fleets. However, there is not the same degree of urgency to implement the programs, because there is significantly less potential for combinations of severe corrosion and fatigue cracking in the younger fleets. Consequently, Boeing is proposing that the CPCPs be incorporated into the basic minimum structural maintenance requirements. Additional guidance material, for use by airlines and regulatory authorities, will also be published.

Most structural behavior can be predicted and validated relatively quickly by analysis and static and fatigue testing. Corrosion behavior can only be confirmed by real time exposure. Consequently, we must rely very heavily on our historical experience, which has shown us that seemingly trivial details sometimes trigger major problems. Boeing has recently developed a comprehensive Corrosion Design Handbook reflecting fleet experience to provide the structural engineer with the same corrosion prevention expertise that parallels methods used to develop producible, durable and damage tolerant structures, Figure 76. While many corrosion problems were addressed in durability design guides, it became apparent from fleet surveys and service experience that a separate and dedicated corrosion prevention resource guide would be more effective. Similarly, improved structural arrangements and concepts will enhance the inherent robustness and forgiveness of the structure, facilitate simpler repairs when damage occurs, and facilitate accessibility and inspectability. The 777 program placed strong emphasis on these issues as the design concepts were finalized.

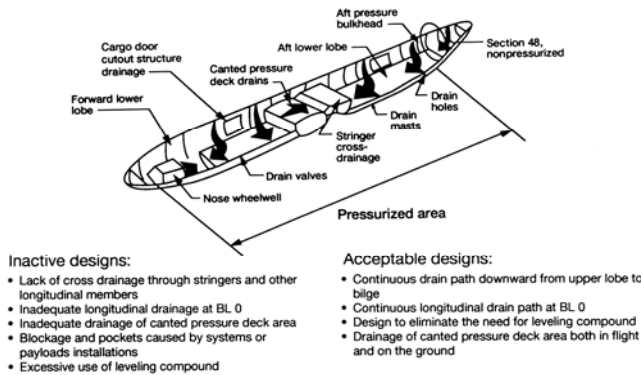

Figure 76. Lower Lobe Drainage Examples in Corrosion Prevention Design Handbook

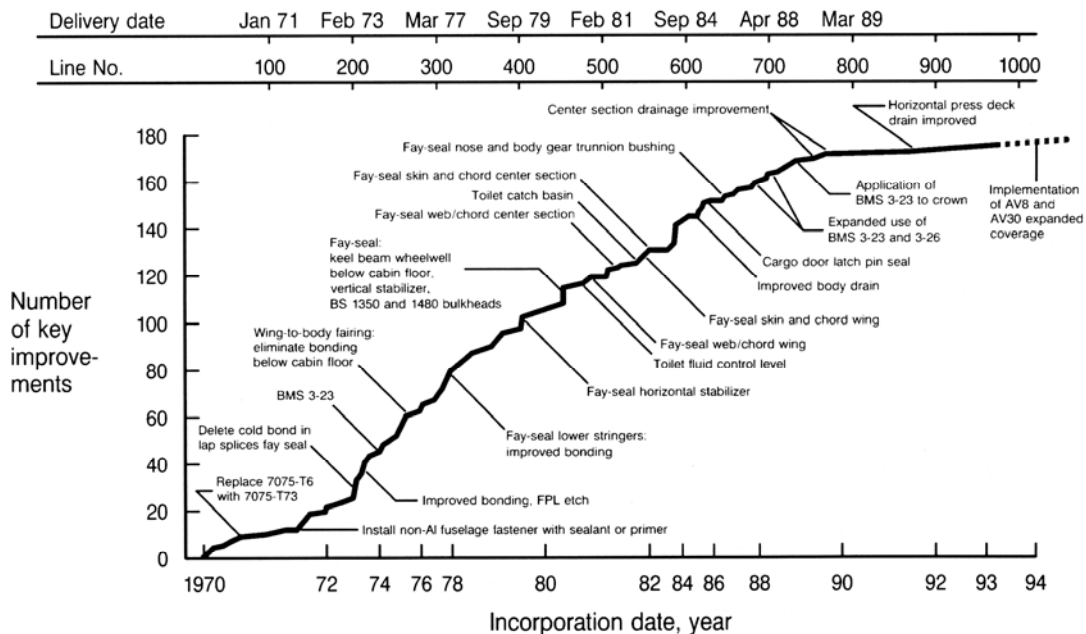

Figure 77. 747 Corrosion Prevention Design Improvement Effects on Service Performance

Many corrosion-related improvements in materials, finishes, processes, and design details have been introduced into the production lines of all existing and new models, Figure 77. These changes were expected to significantly reduce the corrosion problems typically encountered later in service. Figure 78 compares cumulative corrosion events reported by the operators for the pre- and post-improvement 747 airplanes after approximately the first ten years of service. The apparent results are dramatic and very encouraging. However, before becoming too confident of our success, we must be sure that the data represent true airplane condition rather than the results of a relaxed, overconfident reporting system. Consequently, the Boeing Airplane Fleet Survey program was expanded to include surveys of ten-to twelve-year-old airplanes to determine firsthand knowledge of which of these improvements are really proving effective in typical service use. Such data are essential to benchmark our current standards and to develop the proper baseline and objectives for new design and current production models alike.

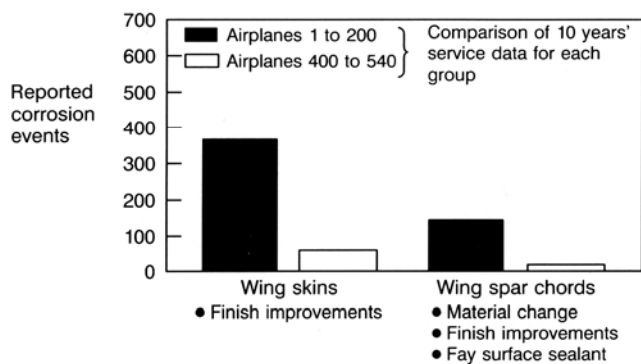

Figure 78. Corrosion Prevention Design Improvements Examples — Model 747

Supplemental Inspection Program Reviews

Supplemental structural inspection documents were released between 1979 and 1983 for all aging Boeing jet transport models. Their purpose was to ensure continued safe operation of the aging fleet by timely detection of new fatigue damage locations. These documents have been updated on a regular basis to reflect service experience and operator inputs. In the light of current aging fleet concerns, these inspection programs were to ensure adequate protection of the aging fleet. The major focus of these reviews was:

- Adequacy of the present fleet leader sampling.
- Inclusion/deletion of principal structural elements (PSE).

The initial candidate fleet leader samples comprised those airplanes exceeding 50% of the design objective in flight cycles when the typical fleet leader reached 75%. These criteria resulted in 461 model 727, 124 model 737, and 117 model 747 subject to SSID compliance.

During the early 1990s, a large number of high-cycle airplanes were being retired or placed in long-term storage.

Many of these were candidate airplanes. The size of the active candidate fleets fell below what the FAA believed to be acceptable levels.

In addition, noncandidate airplanes with high utilization now had more cycles than some of the candidate airplanes. The process for adding new candidates was lengthy because it necessitated an SSID revision requiring STG and FAA approval, as well as a new AD to mandate the changes.

Finally, because of the inspection time lag associated with the implementation rules regarding ownership transfer of candidate airplanes, it was believed that the candidate airplanes were not actually being inspected.

Effective 23 June 1998, AD 98-11-03 (for the 727) and AD 98-11-04 (for the 737) were issued, eliminating the candidate fleet system and implementing a threshold-based system, in which the inspections begin a fixed threshold for these model airplanes. Airplanes exceeding the threshold become a part of the SSID program, Figure 79.

| Model | Inspection Threshold (flight cycles) | Revised Candidate Fleet |
|--------------------|--------------------------------------|-------------------------|
| 727-100/-200: | 55,000 | 275 |
| 727-100C/-200F: | 46,000 | |
| 737-100/-200: | 66,000 | 90 |
| 737-200C: | 46,000 | |
| 737-300/-400/-500: | 66,000* | |
| 747 All models: | 20,000** | 91 |

*Expected threshold

**Wing items - 20,000 flight cycles or 100,000 flight hours whichever comes first

Figure 79. SSID Inspection Thresholds Mandated for Pre-Amendment 45 Certified Airplanes by 1998 Airworthiness Directives

Revisions to 707, 727, 737 and 747 SSIDs included changes to approximately ten significant structural items for each model. Some PSEs were not included in the original SSID on the basis that damage would be obvious before safety was affected. A review of those items resulted in adding several items to the SSID, primarily some hidden wing structure previously deleted on the basis of fuel leaks to signify fatigue damage.

Thin gauge fuselage structure was not included in the initial SSIDs on the basis of test and service evidence that skin cracks would turn at frame locations and result in a safe decompression. Consideration of aging fleet damage in adjacent bays prompted coverage of thin gauge fuselage structure, 1.4 mm thick or less for models 727 and 737. The 747 fuselage skins were already included in the initial SSID because of thicker gauges.

Much concern has been expressed recently regarding possible widespread fatigue cracking, a phenomenon where a patch or group of multiple small cracks of varying sizes in adjacent holes simultaneously join to form a single crack of longer combined length. This results in a substantially

reduced time frame to safely detect the cracking. The SWG concurred that the SSIDs should include considerations for structure susceptible to that form of cracking with appropriate changes of damage detection periods and inspection intervals. Figure 80 shows examples of impact of MSD link-up on damage detection periods and associated cumulation detection probabilities.

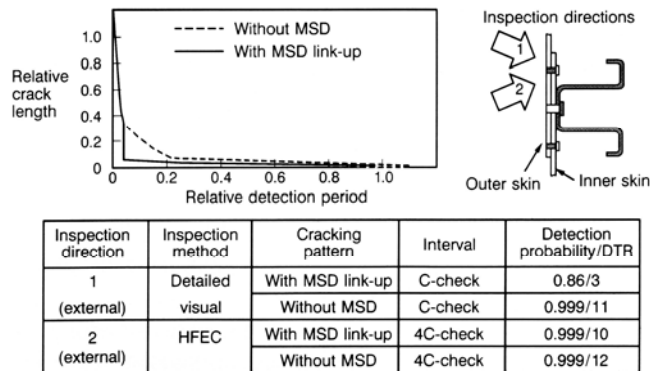

Figure 80. Example of SSID Revisions to Account for Assumed MSD Link-Up in Lap Splices

The original SSIDs allowed credit for detection opportunities based on secondary cracking. Allowing detection credit for secondary skin cracks may be unconservative, especially if the majority of the detection credit was to be derived from external inspection of the skin. For example, when a fuselage frame cracks, the next crack may occur in the adjacent frame rather than in the skin as was assumed. It was agreed that the SSID should be reviewed and revised to cover adjacent member cracking patterns wherever they were likely to occur.

Widespread Fatigue Damage

The present rules for airplane structural design have evolved from successful experience and lessons learned in service. As opposed to earlier commercial airplanes, the first generation of jet transports have not become technically obsolete before portions of the worldwide fleet have reached and exceeded original design service objectives. Dependent damage at multiple sites was recognized in revised damage tolerance regulations in the late 1970s. Independent damage in similar details subjected to similar stresses has long been recognized as a potential continuing airworthiness problem. Fuselage structure is typically more susceptible to WFD because of numerous similar details subjected to pressure cycle loads with moderate flight-by-flight variations.

The Federal Aviation Administration chartered a task force in the mid 1980s to assess large transport category airplanes relative to their potential for widespread fatigue damage and their capability to accommodate controlled fuselage decompression. The team found considerable differences between manufacturer approaches to address WFD in fuselage structures. No evidence was seen at the time that any of the airplanes included in the assessment were operating unsafely because of WFD. The team concluded that sound damage tolerance design principles coupled with

prudent inspection programs and responsive modifications by operators would ensure continued safe operation.

Several concerns were, however, raised by the team:

- Previous geriatric assessments may not have adequately considered the potential for WFD.
- Structural integrity of aging airplanes may in the future be impaired by net section yielding at independent WFD sites or degradation of fail-safety.
- Assessment of WFD should be based on tests or service experience interpreted through teardown inspections.
- The existing data base is insufficient to determine the onset of WFD.

The 1988 accident over Hawaii resulted in airline/manufacturer recommendations for the industry to “continue to pursue the concept of teardown of the oldest airline airplane to determine the structural condition, and conduct fatigue test of older airplanes.” Substantial worldwide industry and regulatory agencies cooperative efforts have since been focused on WFD concerns and recommended actions to ensure continued structural airworthiness of older airplanes.

WFD Concerns. Widespread fatigue damage in a structure is characterized by the presence of multiple structural details with cracks that are of sufficient size and diversity whereby the structure will no longer meet its damage tolerance requirement (e.g., maintaining the required residual strength after partial failure) Figure 9. There are two distinct types of WFD:

- Multiple Site Damage (MSD) — Simultaneous presence of fatigue cracks in the same structural elements.
- Multiple Element Damage (MED) — Simultaneous presence of fatigue cracks in adjacent structural elements.

Dependent types of MSD and MED that are within the extent of existing damage tolerance regulation compliance assumptions are labeled “local.” Such dependent damage is characterized by retention of residual strength capability after link-up of adjacent finite cracks. Independent types of WFD may reduce the residual strength and corresponding critical crack length substantially, Figure 81.

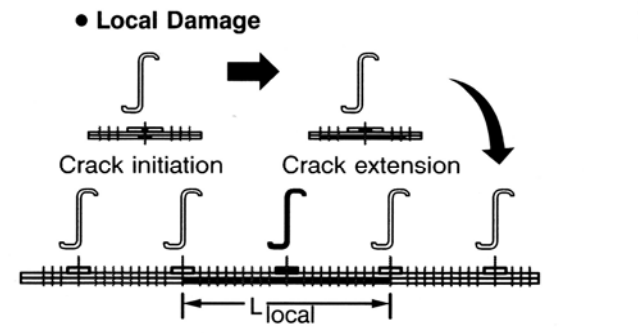

- Maximum allowable damage shown
- Damage connection up to this size is tolerated
- No significant damage beyond this region
- All MSD or MED within this area is local and already accounted for in damage tolerance analysis

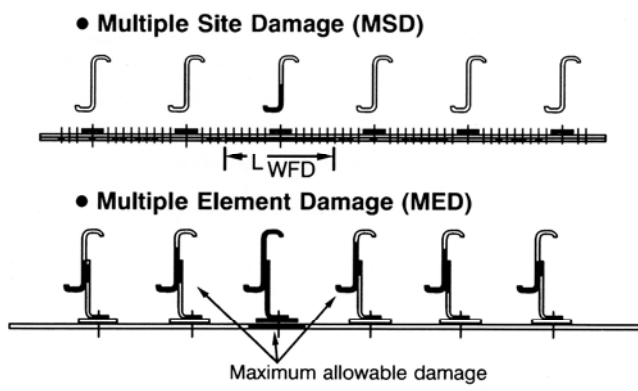

- Widespread similar details
- Similar stresses
- Structural interaction with reduced allowable damage

Figure 81. Example of Local Versus Widespread MSD or MED

The concern for WFD thus exists when large regions with similar structural details and same significantly high stress levels. Coalescence of multiple damage origins may potentially be catastrophic, and there is a lack of confidence in damage detection before such unsafe conditions may develop.

Industry Initiatives. An international task group was chartered in 1990 comprising manufacturers and operators to investigate and propose appropriate actions to address WFD concerns by timely discovery of any aging fleet problems.

The task group reached the conclusion in their first report released in 1991 that while significant improvements in the structural safety system have been introduced by AAWG sponsored initiatives, Figure 65, there is still an outstanding concern for the potential onset and possible non-detection of widespread fatigue damage. Model-specific audits were proposed for those airplanes that have exceeded or approaching their original design service objectives. The elements of the proposed audit process are shown in Figure 82.

- Determine areas potentially susceptible to MSD.
- Determine areas of possible concern for MED.
- Assess each suspect area's level of safety with current and augmented maintenance programs.
- Select areas requiring additional monitoring to establish the required level of safety.
- Determine additional area-specific actions to achieve the required level of safety.
- Implement appropriate actions.

Figure 82. Elements of Model-Specific Audits for MSD/MED

The Structural Audit and Evaluation Task Group, SAETG, performed an extensive data collection and analysis activity to determine candidate options that have applicability to the identified concerns. While all the adopted SAETG options are valid to some extent in predicting the onset and location of multiple site damage and multiple element damage, none of the options provide foolproof safeguards. Ultimately conscientious and reliable inspections of the airplane structure are key to confidence in ensuring continuing airworthiness. Six options were identified as possible candidates singly or in combination to achieve the required level of safety, Figure 83.

- Selected limited nondestructive disassembly, inspection, and refurbishment of high time airplanes continuing in service
- Continuing assessment of the fleet-demonstrated capability through diligent monitoring of service experience
- Fleet exploration of high time airplanes with improved state-of-the-art NDI techniques
- Testing of new or used structure on a smaller scale than full component tests (i.e., subcomponent and/or panel tests)
- Fatigue test of high time airplane or full-scale major component followed by detailed teardown or test article
- Teardown of high time airplane

Figure 83. Model-Specific Candidate Actions to Address Widespread Fatigue Damage Concerns

SAETG is still actively finalizing their WFD audit recommendations. The format of prudent fleet implementation of audit recommendations is still not resolved. Updates of existing SSID and service bulletin modification programs appear as the most responsive corrective action today for tomorrows possible problems. Boeing and some other manufacturers have performed WFD audits of their aging fleets.

An outcome of the initial SAETG report discussed above was the formulation of a long-term cooperative program between major airplane manufacturers in Europe and the United States with focus on improving the knowledge about WFD phenomena and to compile and develop methods for

assessment. The short term objectives of this committee were completed in 1992. The long term objectives are focused on shortfalls and proposed actions to enhance WFD evaluations.

One concept which has come out of the research and development effort into widespread fatigue is the Limit of Validity (LOV) of an airplane's maintenance program. This is a point in an airplane's operational life beyond which there may be insufficient engineering data to support continued operation due to fatigue considerations. In other words, the inspections in the maintenance program may not detect fatigue damage before the strength levels are reduced below the regulatory requirements. The issue of WFD for each model airplane will be addressed in a document which will contain the LOV, and any modifications and inspections required to alleviate the concern over WFD. The FAA is considering the issuance of a FAR PART 121/129 rule to mandate inspection programs and the LOV for each model. The LOV may be extended if additional information such as new fatigue test data becomes available.

| Model | Preliminary LOV* | Airplanes above LOV | Projected above LOV in 2011 |
|-------------|-----------------------------------|---------------------|-----------------------------|
| 707 | 40,000 f/c | 0 | 0 |
| 727 | 100,000 f/c | 0 | 0 |
| 737 | 100,000 f/c | 0 | 10 |
| 747 Classic | 30,000 f/c | 40 | 59 |
| | 115,000 hours | 5 | 47 |
| | 35,000 f/c _{extended} | 9 | 28 |
| | 135,000 hours _{extended} | 0 | 5 |
| 747-400 | 35,000 f/c | 0 | 0 |
| | 165,000 hours | 0 | 0 |

*Subject to FAA approval

Figure 84. Limit of Validity (LOV) of Airplane Maintenance Programs

The establishment of an LOV also requires the modification of the maintenance program to ensure that any known or predicted occurrence of MSD or MED are found and corrected before the structure is impaired. The AAWG has established guidance material for the development of maintenance programs addressing MSD or MED. The guidance is directed towards individual details within the airplane and as such is not associated with the LOV, which is an airplane model specific characteristic.

The AAWG Guidance material requires determination of the following information for each MSD or MED susceptible area, Figure 85.

Inspection Start Point (ISP): is the point in time when special inspections of the fleet are initiated due to a specific probability of having a detectable MSD/MED condition.

Structural Modification Point (SMP): is a point reduced from the WFD average behavior (i.e., lower bound), so that operation up to that point provides equivalent protection to that of a two-lifetime fatigue test. No airplane may be operated beyond the SMP without modification or part replacement.

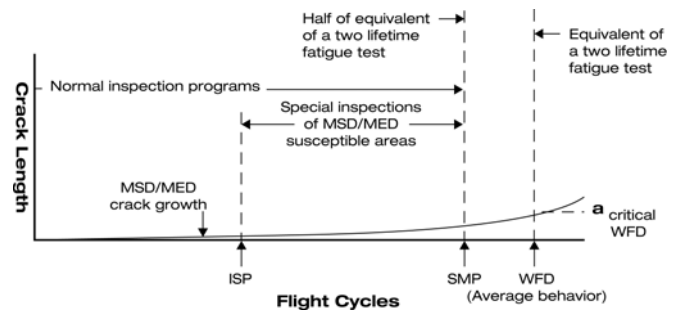

Figure 85. ISP and SMP Graphical Representation

Structures Susceptible to WFD. The manufacturers have addressed several issues as part of the short term objectives ranging from definitions of WFD, definition of structural parts susceptible to WFD, review of industry experience and practices for analyses of WFD to establish long term goals.

Structure susceptible to WFD has the characteristics of similar details operating at similar stresses where structural capability could be affected by interaction of similar cracking. Thirteen types of structure potentially susceptible to WFD have been identified by the manufacturers' committee. These types are the result of comparing and classifying the overall full-scale test and in-service experience of the involved manufacturers. The following structures are identified as potentially susceptible to WFD:

- Fuselage
 - Longitudinal skin joints, frames and tear straps.
 - Circumferential joints and stringers.
 - Frames.
 - Aft pressure dome outer ring and dome web splices.
 - Other pressure bulkhead attachment to skin and web attachment to stiffener and pressure decks.
 - Stringer to frame attachments.
 - Window surrounding structures.
 - Over wing fuselage attachments.
 - Latches and hinges of non-plug doors.
 - Skin at runouts of large doublers.
- Wing and Empennage
 - Chordwise splices.
 - Rib to stiffener attachments.
 - Skin runouts of large doublers.
 - Stringer runouts at tank end ribs.

In addition the type of WFD (i.e., MSD and/or MED) the critical locations and existing experience of factors that influence MSD and/or MED were determined. The above mentioned list is of a global nature covering all possible areas which may not be critical at each individual airplane model.

Two examples are shown in Figures 86 and 87 summarizing the industry experience regarding longitudinal skin joints including frames and tear straps and aft pressure dome outer ring including dome web splices. Both figures show several

different design configurations with corresponding critical locations.

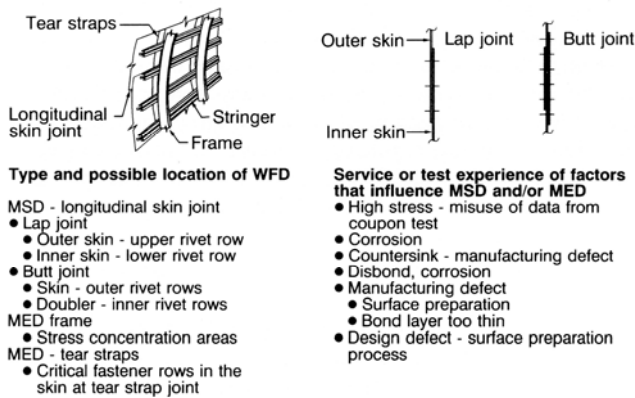

Figure 86. Structures Potentially Susceptible to WFD — Longitudinal Skin Joints, Frames and Tear Straps Examples

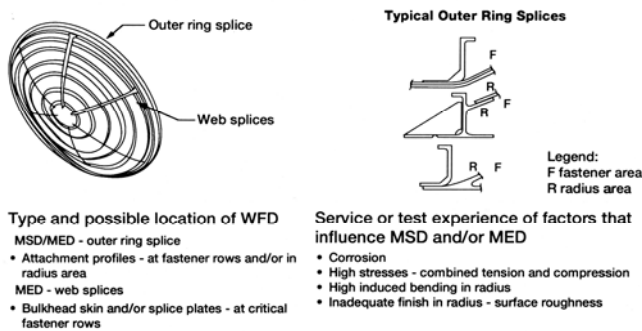

Figure 87. Structures Potentially Susceptible to WFD — Aft Pressure Dome Outer Ring and Dome Web Splices Examples

The listing of the factors influencing MSD and/or MED comprises the experience of the different manufacturers and may not be applicable to each individual airplane model.

WFD Failure Mechanisms. Continuing structural airworthiness of damage tolerant structures depends on prudent inspections and/or modifications as airplanes approach cracking thresholds. Dependent and local damage at multiple sites have been addressed in existing supplemental inspection programs. Some structures described above are susceptible to independent widespread fatigue damage, and there is a lower confidence in timely and safe detection of WFD in comparison to local damage patterns. Considerable research and scientific interest has emerged in crack growth predictions for multiple site damage scenarios. While this information may be of some value for structural damage detection assessments, the key safety focus involves the estimates of when WFD may be significant and what impact such WFD may have on the residual strength of the structure.

Typically, inspection thresholds are defined as specific flight cycles or flight hours at which the first supplemental inspection should take place. For practical purposes, a more meaningful definition is required. If crack detection

probability is very small, inspection efforts are wasted. It appears reasonable to select these thresholds to reflect approximately five percent of the MSD elements with cracks.

Extensive WFD may be accompanied by a rapid decrease in residual strength as shown schematically in Figure 9. Simplified analysis assumptions and supporting test evidence show that the residual strength is determined primarily by the size of the main crack and the distance to the MSD location. This supports the need to take appropriate action to preclude MSD since it cannot be allowed to develop much beyond local boundaries.

An unstiffened panel with a center crack and equal MSD at each fastener hole is shown in Figure 88. Assumed MSD ahead of the crack will cause interaction and increased crack tip stress intensities for the main crack and the adjacent MSD cracks. A net section stress criteria between the crack tips is used to predict crack extensions. The resulting residual strength line is shown in Figure 89 for various MSD crack sizes. It is important to recognize that the influence of widespread fatigue damage cracking in built-up structures with associated load redistributions may be significantly different from unstiffened panel behavior discussed above. The fact remains that the residual strength of the lead crack is not very sensitive to the MSD crack size. Panel test data shows a similar trend supported by net section failure criteria discussed above, Figure 90.

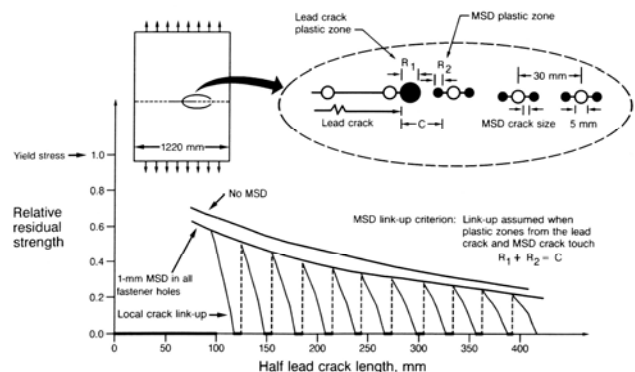

Figure 88. Residual Strength of an Unstiffened Panel Containing MSD at Each Fastener Hole

Stiffened structure resistance to WFD is dependent on inherent crack arrest capability for local damage. The crack arrest ability is heavily influenced by stiffener/frame combination in terms of material and geometry selection. Structure with frames against the structure is more efficient than straps alone or with floating frames away from the skin. As will be shown in the following simplified examples, crack arrest capability can be provided for structure with WFD. However, existing older structural fail-safe designs may need affirmative inspection/modification actions to address WFD concerns.

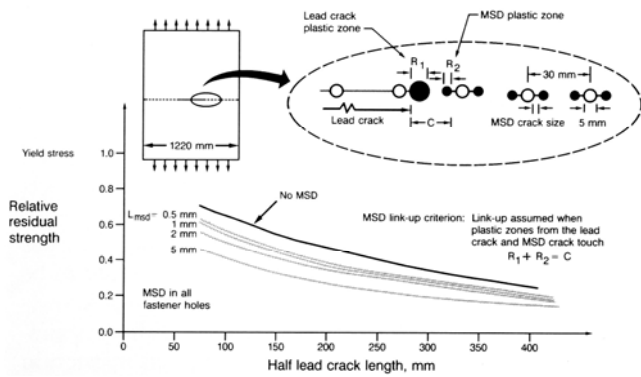

Figure 89. Residual Strength of an Unstiffened Panel Containing Various MSD Sizes

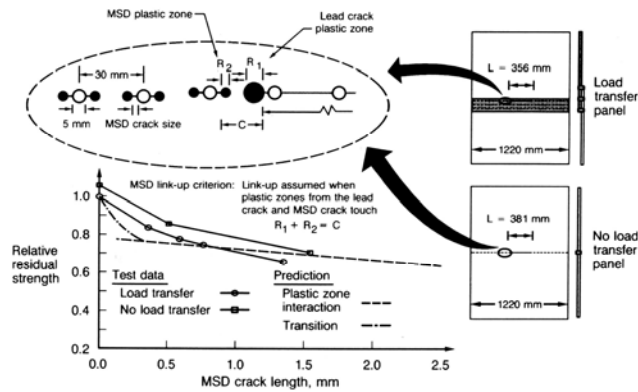

Figure 90. Test and Predictions of Failure Stresses for Flat Panels Containing MSD at Each Fastener Hole

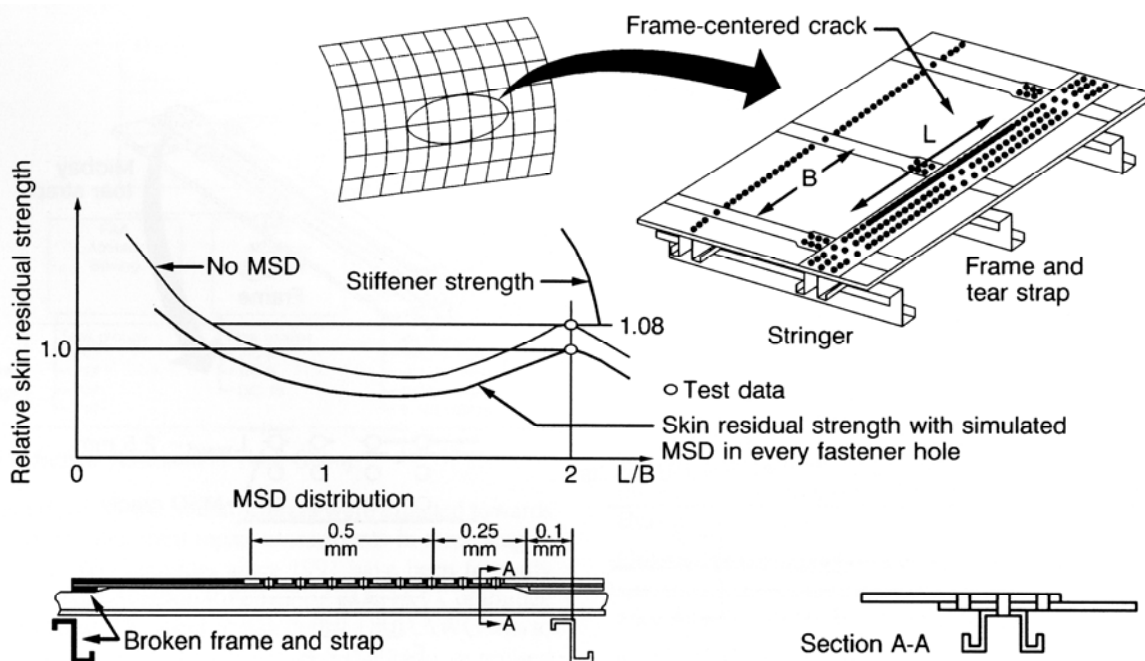

Figure 91. Residual Strength of a Stiffened Panel Containing a Frame Center Crack Along the Lap Joint With Varying MSD Distributions

An example of a stiffened fuselage structure is shown in Figure 91. Crack arrest in the presence of MSD becomes significantly more complex but the same principles apply. The interaction from small adjacent cracks are accounted for by appropriate stress intensity factor corrections. Again, the net section failure criteria will prevail as the lead crack approaches the adjacent MSD cracks. After link-up, the crack is arrested if the stiffening elements have sufficient residual strength in the presence of dependent local damage, Figure 92. Variation of MSD crack sizes corresponding to local stress distributions may further alleviate the influence of MSD by reduced sizes close to frame/strap locations, Figure 91. Several full-scale stiffened panels have been tested with and without MSD ahead of the lead crack. Figure 93 shows one example of test/analysis correlation for a lap splice test configuration.

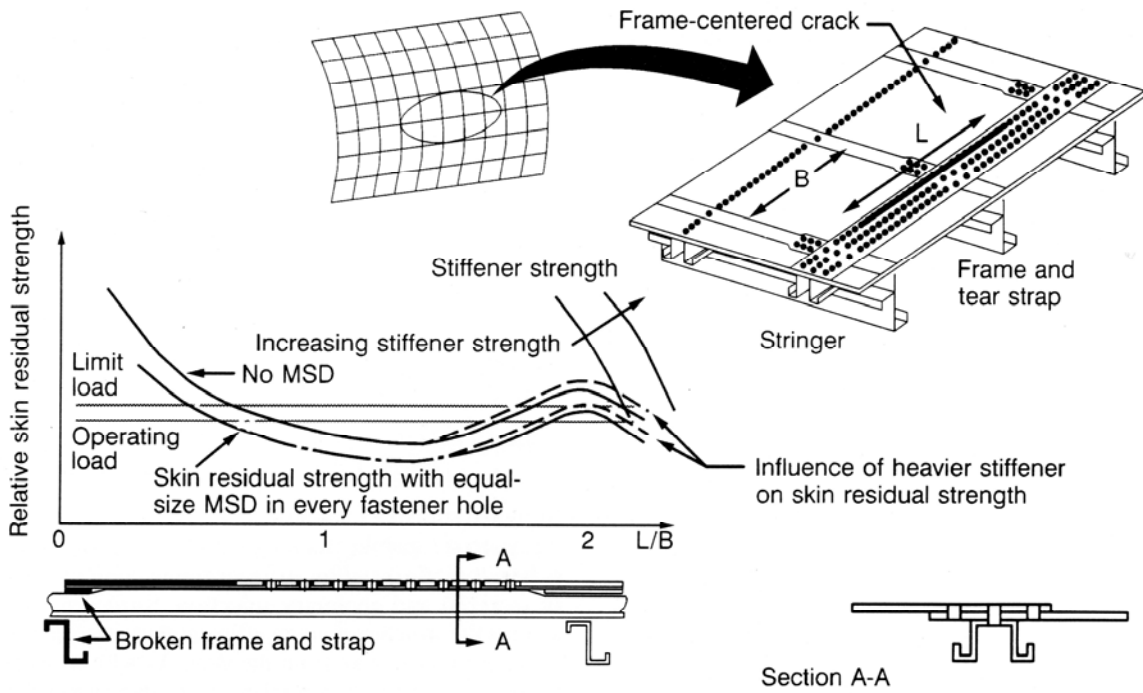

Figure 92. Stiffening Influence on Residual Strength in the Presence of MSD

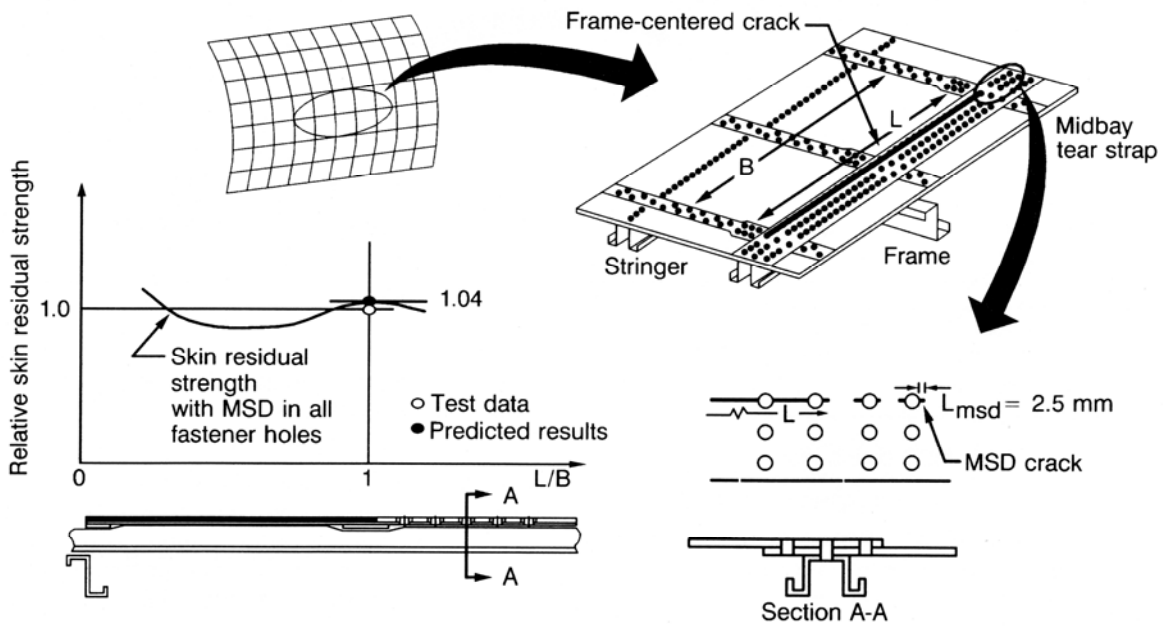

Figure 93. Residual Strength Test/Analysis Comparison for a Stiffened Panel

Structural Repair Assessments

Inevitably, airplanes accumulate repairs. For each model, structural repair manuals (SRM) assist the operator in ensuring that typical repair action maintains the airframe structural integrity. Other larger repairs are handled by individually prepared and approved engineering drawings. Traditionally, these repairs have primarily focused on static strength and fail-safe aspects of the structure after repair, with commonsense attention to durability considerations. For several years, however, there has been an additional emphasis on the need for structure to be damage tolerant. Achieving damage tolerance demands knowledge of potentially critical structural elements, an understanding of damage growth and critical size, and an inspection program to ensure timely detection.

Repairs may affect damage tolerance in different ways. An external repair patch on the fuselage can hide primary structure to an extent that supplemental inspections may be required, Figure 94. Other repairs may interfere with obvious means of detecting damage such as skin repairs on the lower wing with sealant that prevents fuel leakage. Repairs located in low stress areas with slow crack growth rate can have damage tolerance provided by existing maintenance.

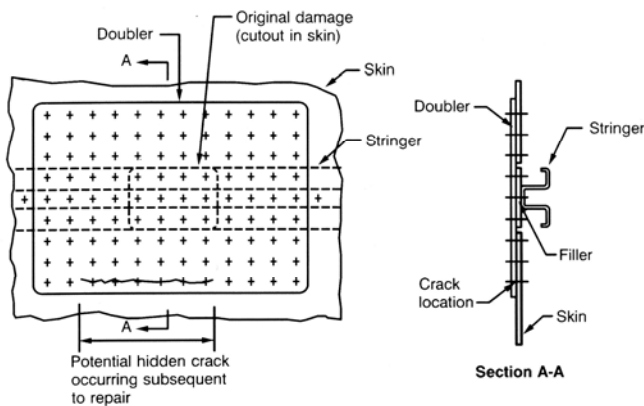

Figure 94. Typical Fuselage External Skin Repair

Industry Activities. System changes to enhance continued structural airworthiness of aging airplanes included repair assessment, Figure 65. Several Structures Task Groups (STG), manufacturer and AAWG subcommittee meetings were held during 1990 and 1991. Industry concern for the direction of these activities resulted in formation of the Repair Assessment Task Group (RATG), Figure 95. The following sections describe the RATG charter and progress towards resolving key issues in order to achieve commonality of approach without undue burden for the operators. The thrust of these activities have been focused on updates of the Structural Repair Manuals (SRM) and model specific repair assessment documents approved by the FAA.

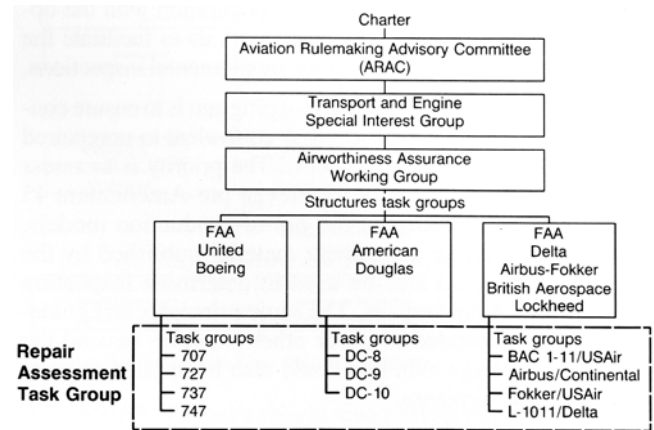

Figure 95. Repair Assessment Task Group

The initial efforts by the manufacturers were directed towards development of consistent repair assessments in three stages. The AATF/AAWG activities since 1991 have been formally incorporated in the Aviation Rulemaking Advisory Committee (ARAC) structure. The specific task defined by AAWG was to develop recommendations concerning whether new or revised requirements and compliance methods for structural repair assessments of existing repairs should be initiated and made mandatory for eleven aging fleet models. Specific tasks and timelines for the Repair Assessment Task Group (RATG) have also been identified including:

- Develop procedures and criteria to assess existing repairs for long term continued operation of eleven pre-Amendment 45 airplanes.
- Evaluate and determine if any rulemaking is recommended for assessments of existing repairs.
- Provide recommendations to the AAWG Steering Committee. Support the development of recommendations to the Transport Airplane and Engine Issues Group (TAES) of ARAC by mid 1993.

Rules and guidelines that address repairs on airplanes being certified today are broadly based on certification and operational requirements. A review of these documents indicate that airplanes certified under these regulations require structural repairs that restore both static strength capability, and damage tolerance and fatigue strength capability. There is also guidance material which requests an evaluation of needs for supplemental inspections to detect premature degradation of structural damage tolerance capabilities as a result of repair installations. Furthermore, there are regulations that would allow for the mandatory compliance of any special inspection programs developed as part of the requested repair installation evaluation.

For airplanes certified before FAR 25.571 Amendment 45, the rules governing repairs were less restrictive. Basically, these rules only required repairs that restored structural static strength. The advent of the Supplemental Structural Inspection Programs (SSIPs), per AC 91-56, in the 1980s combined with other revisions to FAR Part 43 required

supplemental inspections of certain structure called Principal Structural Elements (PSEs). The concepts of the SSIP are similar in nature to the new airplane Airworthiness Limitations Instructions under FAR 25.1529. In 1991, the FAA published AC 25.1529 which addresses the approval procedures to follow when making structural repairs to airplane type designs with Supplemental Structural Inspection Documents (SSIDs). This guidance material requested that repairs to PSEs be initially proven to meet static strength requirements before return to service and a continued airworthiness assessment to be completed within a one year time frame. Any supplemental inspections required for the particular repair would also need to be developed.

Today's operational rules are similar for both the pre- and post-Amendment 45 airplanes in regards to performance standards that an airline must adhere to in repairing or altering an airplane. Currently the FAR or any guidance material does not address retroactive rules regarding the continued airworthiness of repairs previously installed on pre-Amendment 45 airplanes.

Repair Assessment Approach. Criteria and a five-step approach was established for repair assessments by AAWG in December 1991.

Criteria for developing guidance material for repairs requiring specific maintenance programs to maintain the damage tolerance integrity of the basic airframes can be summarized as:

- Specific repair size limits should be selected for each model of airplane.
- Repairs which have been superseded require review.
- Repairs in close proximity may jeopardize the continued airworthiness of the airplane.
- Repairs that do not conform to SRM standards may require further action.
- Repairs which exhibit structural distress should be replaced before further flight.

It became clear that more fleet evidence was required to scope the overall problem in terms of any continued airworthiness concerns. This resulted in formulation of a five-step AAWG approach to repair assessments in December 1991:

1. Develop model-specific guidance using AAWG repair criteria.
2. Survey a number of operators' airplanes to:
 - Assesses fuselage skin repairs below window belt.
 - Validate approach.
 - Form basis for broader effort.
3. Develop worldwide survey if required.
4. Collect and assess results to determine further course of action by mid 1992.

5. Develop specific manufacturer/operator/FAA actions.

Repair Surveys. Structures Working Groups chairmen for the eleven pre-Amendment 45 airplanes formed repair survey teams (essentially expansion of RATG) to conduct sample surveys of fuselage repairs located below the window belt. The surveys were performed on airplanes stored at Mojave, California, and Amarillo, Texas, and coordinated with airplane owners by the FAA. Each team comprised representatives from the FAA Aircraft Certification and Flight Standards Office, operators and manufactures. The survey teams used the following procedures:

- Survey and document lower surface fuselage repairs on selected Airbus, Boeing, Douglas and Lockheed airplanes.
- Categorize repairs in three groups using engineering judgment and applicable AAWG screening criteria:
 - No additional action required (Category A).
 - Repair may require supplemental inspection for damage tolerance (Category B and C).
 - Remove and replace repair with Category A, B or C repair.

A total of 356 repairs were evaluated on 30 airplanes over a three-day period. Five different teams comprising engineers conducted these surveys which provided firsthand observations of service repairs in terms of type, proximity, condition and number of repairs relative to standardized common criteria. These surveys demonstrated that some repairs of good quality may inhibit damage detection during normal maintenance activities and therefore may need supplemental inspections due to size, configuration and/or proximity considerations.

These fuselage repair surveys did not indicate an immediate concern for continued structural airworthiness. The size distribution of repairs, Figure 96, indicated a need for assessments to establish inspection requirements for larger repair and/or smaller repairs in close proximity. Operators need updated SRMs and model-specific guidance documents to accomplish their repair assessments.

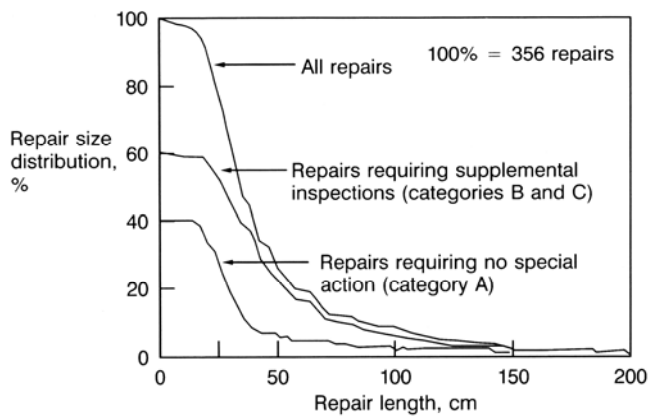

Figure 96. Fuselage Repair Size Distributions Based on Fleet Surveys

The surveys also indicated that it would be premature to mandate assessments of repairs in view of existing regulations. The scope and effectivity for existing mandatory structural modification programs and corrosion prevention and control programs are also important considerations in establishing any need for additional regulatory actions.

Repair Assessment Process. This section describes the elements of the repair assessment process. The manufacturers should provide SRM updates and model-specific repair assessment documents. Operators should assess existing repairs to determine which permanent repairs require supplemental inspections beyond specific thresholds. Temporary repairs may also need supplemental inspections before they reach their replacement threshold. The manufacturers should develop Baseline Zonal Inspections (BZI) in cooperation with the operators, reflecting typical inspection intervals to facilitate the classification of repairs and need for supplemental inspections.

The objective of the repair assessment program is to ensure continued structural repair airworthiness equivalent to unrepaired similar principal structural elements. The priority is to assess pressurized fuselage repairs for eleven pre-Amendment 45 airplanes with emphasis on the out-of-production models. Model-specific repair assessment material published by the manufacturers could also be used to determine inspection requirements for new repairs. The same principles and guidelines may be expanded to cover other structure beyond the pressurized fuselage skin and could also be applied to post-Amendment 45 airplanes.

The assumed BZI reflects typical existing maintenance inspections performed by most operators, Figure 97. These BZIs serve as an evaluation tool for some manufacturers to establish criteria for supplemental inspections, repair size limits, etc. Some manufacturers have developed the BZI in conjunction with Structures Task Group (STG) meetings. The BZI provides opportunities to simplify the repair screening process with regard to structural locations based on stress environment and zonal critical details.

| Structure (surveillance inspection) | | Baseline inspection intervals (flight cycles) | |
|-------------------------------------|---------------------------|---|------------------|
| Wing | External | 3,000 | |
| | Leading-edge cavity | 3,000 | |
| | Trailing-edge cavity | 3,000 | |
| | Wing box (internal) | Outboard Center section | 15,000 20,000 |
| Fuselage | Upper lobe external | 6,000 | |
| | Lower lobe external | 3,000 | |
| | Upper lobe internal | 20,000 | |
| | Lower lobe internal/bilge | 15,000/9,000 | |
| | Section 48 internal | 6,000 | |
| Empennage | External | 3,000 | |
| | Internal | Vertical stabilizer | 20,000 |
| | | Horizontal stabilizer | 20,000 |
| Strut | | 15,000 | |

Figure 97. Assumed Baseline Zonal Inspection Intervals for 727 Repair Assessments

Structural Repair Manual Updates. Model-specific Structural Repair Manuals (SRM) should be updated by the manufacturers to reflect damage tolerance repair considerations. The goal is to complete these updates within one year of adoption of the RATG recommendations with initial emphasis on fuselage pressure boundary structure.

The general section of each SRM will contain brief descriptions of damage tolerance considerations, categories of repairs, description of assumed baseline inspections, and repair assessment stages, Figure 98. Data for pressurized fuselage skin will be provided initially to identify repair categories and related information.

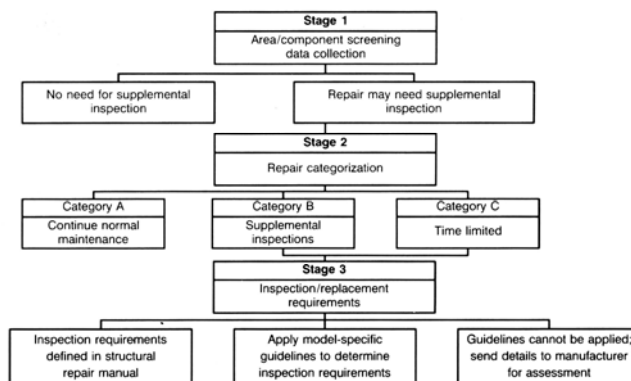

Figure 98. Repair Assessment Stages

Generic SRM repairs should also contain repair category considerations regarding size, zone and proximity. Detailed information for determination of inspection requirements should be provided in separate guidance material for each model. Unsatisfactory repairs should be labeled inactive and remain in the SRM. Inspection and replacement requirements for these repairs will be added to the SRM. Updates of SRM should be FAA (or equivalent) approved in line with current practice for revision approvals.

The manufacturers should also review and determine requirements for supplemental inspections if not already adequately addressed in Service Bulletins. Terminating action to Airworthiness Directives which modifies structure does not always contain instructions for future supplemental inspection requirements.

Repair Assessment Guidance Material. Separate model-specific documents outside the SRM should be prepared by the manufacturers for the eleven aging airplane models. Uniformity/ similarity of these repair assessment procedures are important to simplify operator workload. The manufacturers have spent considerable time over the last three years to achieve commonality of the repair assessment process.

Thresholds for assessments of existing repairs are based on fatigue damage considerations and specified for each model in flight cycles. While threshold recommendations vary between manufacturers, they are typically 75% of design service objectives, Figure 99.

| Manufacturer | Model | Threshold [▷] (flights) |
|-------------------|------------|----------------------------------|
| Airbus | A-300-B2 | 32,000 |
| British Aerospace | BAC 1-11 | 60,000 |
| Boeing | 707 | 15,000 |
| | 727 | 45,000 |
| | 737 | 60,000 |
| | 747 | 15,000 |
| McDonnell Douglas | DC-8 | 30,000 |
| | DC-9/MD-80 | 60,000 |
| | DC-10 | 30,000 |
| Fokker | F-28 | 60,000 |
| Lockheed | L-1011 | 27,000 |

[▷] Assessment of existing repairs recommended at next major (D-check equivalent) check or threshold, whichever is later.

Figure 99. Typical Manufacturer Repair Assessment Threshold Recommendations

The SRM and guidance material describes rationale for repair Categories A, B and C:

- Category A
A permanent repair for which the Assumed Zonal Inspection is adequate to ensure continued airworthiness (inspectability) equal to unrepaired surrounding structure.
- Category B
A permanent repair which requires supplemental inspections to ensure continued airworthiness.
- Category C
A temporary (time limited) repair which requires supplemental inspections to ensure continued airworthiness. Thresholds for rework or replacement will be provided in addition to supplemental inspection threshold and interval.

The process involves the following three stages, Figure 98:

- Stage 1
This stage specifies what structure should be assessed for repairs. If a repair is structure in an area of concern the analysis continues; otherwise, the repair does not require classification per this program.
Repair details are collected for further analysis in Stage 2. Repairs which do not meet the static strength requirements or are in a bad condition are immediately identified, and corrective actions must be taken before further flight.
- Stage 2
The repair categorization is determined by using the data gathered in Stage 1 to answer simple questions regarding structural characteristics.
Well-designed repairs in good condition meeting size and proximity requirements are Category A. The process continues for Category B and C repairs.
- Stage 3
The supplemental inspection and/or replacement requirements for Category B and C repairs are determined in this stage. Inspection requirements for the repair are determined by a simple calculation or by using predetermined values (manufacturer specific).
Incorporating the supplemental inspection requirements into the operators' maintenance program completes the repair assessment process.

Repairs which do not meet static strength requirements must be reworked or replaced with A, B or C repairs prior to further flight. Since existing regulations apply, no specific categorization is required for such repairs. Simple condition and design criteria questions are provided in Stage 2 to define the lower bounds of Category B and Category C repairs. Using Category A fuselage skin repairs is encouraged unless operator convenience and scheduling dictates Category C selection.

Guidance material documents for each model will provide a list of structure for which repair assessments are required. Some manufacturers have reduced this list by determining the inspection requirements for critical details. If the requirements are equal to normal maintenance checks, those details were excluded from this list. Figure 100 shows one example of a model-specific repair assessment guidelines for inspection interval selections.

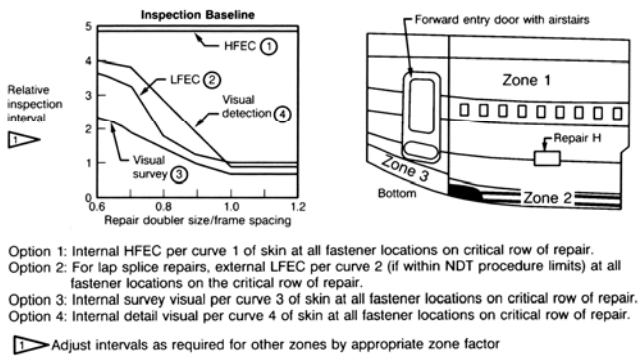

Figure 100. Inspection Options for Fuselage Skin Repairs Requiring Supplemental Inspections

The inspection intervals are based on residual strength, crack growth and inspectability evaluations. The inspection methods and intervals should be compatible with typical operator maintenance practice. Internal inspections are acceptable at D-check intervals while simpler external inspections can be accommodated at multiple C-check intervals.

Repair Assessment Program Implementation. In 1998, the FAA released a Notice of Proposed Rulemaking (NPRM) for the Repair Assessment Program and also conditionally approved the guidelines documents from all the manufacturers until the final rule could be issued.

In April, 2000, the FAA released their final rule on repair assessment for pressurized fuselages effective on May 25, 2000. About the same time, the 707, 727, 737, and 747 guidelines documents were revised to incorporate new test findings, which would be reflected in lowered thresholds for certain repairs where the doubler thickness was much higher than the skin thickness. The documents were also updated to correct minor errors, incorporate customer requests for clarification, and generally improve their usability. The revised 707, 727, 737 and 747 documents were given final approval on February 22, 2001. Revisions of the documents for the DC-8, DC-9, MD-80 and DC-10 were approved by the FAA in February, 2001.

FAR 25.571 amendment 45 introduced the damage tolerance requirement for new airplanes. This was followed by FAR 25.1529 amendment 54 which introduced the requirement for a document which contained instructions for continued airworthiness. The whole airplane is certified to be damage tolerant including repairs. FAA AC 91-56 provides guidance for the development of a program for airplanes certified prior to FAR 25.571 amendment 45. The Supplemental Inspection Document (SID) is the program developed for Douglas designed airplanes using damage tolerance. The applicable Douglas designed airplanes are the DC-3, DC-6, DC-8, DC-9, DC-10 and MD-80. The damage tolerance characteristics of Boeing designed airplanes are addressed by the Supplemental Structural Inspection Document (SSID).

The airplane original structure and some modifications are evaluated for damage tolerance. Repairs are generally not

included in either the SID or the SSID which are mandated by the FAA with Airworthiness Directives.

Repairs installed on pre-amendment 45 airplanes are typically designed to restore the repaired structure to the original type design. In the case of the Douglas designed airplanes (DC-8, DC-9, DC-10, MD-80) and the Boeing designed airplanes (707, 727, 737, 747) the type design includes static strength with fail safe capability restored by a repair. These repairs used “Normal Maintenance” to maintain the continued airworthiness of the airplane. “Normal Maintenance” was based upon operator experience for the airplane.

The Repair Assessment Program defines what the maintenance requirements are for repairs to the pressurized fuselage boundary. The maintenance requirements are based upon damage tolerance and fatigue. All repairs have maintenance requirements and the requirements will range from “Normal Maintenance” to a non-destructive inspection procedure with a specified interval.

FAR Parts 91.410, 121.370, 125.248 and 129.32 require the incorporation of a Repair Assessment Program for airplanes operated under those rules. This is a partial quote from FAR 91.410. The other FARs are approximately the same. The FAA Aircraft Certification Office or office of the Transport Airplane Directorate having cognizance over an airplane type certificate must approve the repair assessment guidelines.

Three main elements of compliance include responsibility (FAA, Operator and Original Equipment Manufacture), timeframes and program elements.

The publication of the final rule in the United States of America’s Federal Register, Volume 65, number 80 dated April 25, 2000 contains background of the final rules, responses to comments and the final rules. These three elements are discussed in the publication of the final rules.

CONCLUSIONS

Timely damage detection is the key element in ensuring structural damage tolerance. This review has been focused on the evolution of damage tolerance principles gained from the failsafe approach, which has worked well for current commercial airliners. Extensive testing, analysis and service records have been employed to provide new technology and procedures that meet damage tolerance regulations for new and aging jet transports. Damage detection assessments for environmental, accidental and fatigue damage sources should reflect a rational coupling between structural characteristics and maintenance program parameters.

Damage tolerance verification includes assessments of allowable damage, damage detection periods for different cracking patterns, and inspection program efficiency. Traditional fracture mechanics research and applications tends to focus on structural characteristics, and the practicing engineer is often encouraged to recommend inspections based on simple factoring of damage detection periods. This practice tends to result in variable and unknown damage detection reliability levels. The impact of access and inspectability as well as contributions from normal maintenance activities are also ignored in some of these simplified inspection recommendations. This review has provided some examples of a more rational approach to development of flexible maintenance programs without compromising safety.

Continuing airworthiness challenges for aging airplanes have been addressed over the last fifteen years. Aging fleet concerns have resulted in joint industry, operator and airworthiness authority actions. The initiatives of these task forces have primarily addressed damage tolerance issues and in many ways sorted out facts and fiction. Mandatory modifications in lieu of continued inspections as well as mandated corrosion prevention programs are examples of prudent actions to permit continued safe operation of jet transports until their retirement from service for economic reasons.

Additional challenges of local damage tolerance capabilities have been addressed in recent years to establish positive initiatives to control widespread fatigue damage effects on continuing airworthiness. Much research is progressing but often is not focused on key problem areas (i.e., WFD influence on residual strength). Recent industry task force initiatives are, however, slowly influencing the thrust of the research community toward the right problems to be solved.

The design, construction, operation and maintenance of airplanes take place in a changing and dynamic arena, with new technology needs and new players. The structural safety system may never be perfect, but it has produced an enviable record. As noted above, damage detection is a key element of damage tolerance assurance. Vigilance must be exercised to maintain focus on prudent inspections and preventive actions for environmental, accidental and fatigue damage. The value of visual inspections is omnipotent and deserves more recognition from the research community in terms of characterization and quantification of damage detection probabilities.

If the lessons learned to date by the manufacturers, the operators and the authorities are properly reflected in next generation airplanes, true and balanced structural damage tolerance will be achieved during longer service periods with progressive maintenance, which ensures continued structural airworthiness until airplane retirements from service for economic reasons.

CURRICULUM VITAE - Jacobus Schijve

12 May 1927, Oostburg, The Netherlands



EDUCATION

- 1953 Masters degree: Delft University of Technology, Faculty of Aerospace Engineering
1964 Doctor of Technical Sciences, Delft University of Technology

CAREER

- 1953 National Aerospace Laboratory NLR, Amsterdam/Noordoostpolder. Last position: Head of the Division of Structures and Materials.
Main topics of research: Fatigue and fracture of aircraft materials and structures, variable-amplitude tests, flight-simulation tests, full-scale fatigue tests, fatigue crack growth, accident investigations, fractography, non-destructive testing.
- 1973 Professor of Aircraft Materials, Delft University of Technology. Main topics of research: same as at NLR, in addition research on the development of fatigue resistant fiber-metal laminates.
- 1992 Emeritus professor. Research, in co-operation with Professor Rinze Benedictus, Head of the Structures and Materials Laboratory and of the Faculty.

FUNCTIONS

- Head of the Division of Structures and Materials of the National Aerospace Laboratory NLR
- National Delegate and General Secretary of the International Committee of Aeronautical Fatigue
- Director of Delft University of Technology TopTech courses on Damage Tolerance of Aircraft Structures.

PUBLICATIONS

- About 130 publications in the open literature (Journals, Symposium books, Conference Proceedings).
- Various Reports and Memoranda of the National Aerospace Laboratory NLR and the Delft University of Technology, Faculty of Aerospace Engineering.
- Several contributions to international seminars and post academic courses.
- Member of the Editorial Board of Fatigue and Fracture of Engineering Materials and Structures
- Author of a textbook on Fatigue of Structures and Materials
- Co-editor of two International Committee of Aeronautical Fatigue (ICAF) books
- Co-author - Damage and Fatigue Crack Growth of Aircraft Materials and Structures

AWARDS

- Georgius Agricola medal
- Cristoforo Colombo medal
- Plantema Memorial Lecture medal
- Member of the Bataafs Gezelschap der Proefondervindelijke Wijsbegeerte
- Knight of the Order of the Lion of the Netherlands
- Elected Fellow of the International Fatigue Series
- Award of Merit of the European Structural Integrity Society
- John W. Lincoln Award – United States Air Force
- Medal of the Delft University of Technology
- Medal of the Faculty of Aerospace Engineering, Delft University of Technology

FUNCTIONS

- Head of the Division of Structures and Materials of the National Aerospace Laboratory NLR
- National Delegate and General Secretary of the International Committee of Aeronautical Fatigue
- Director of Delft University of Technology TopTech courses on Damage Tolerance of Aircraft Structures.

PATENTS

- Two patents of ARALL (Aramid Reinforced Aluminium)

PLANTEMA MEMORIAL LECTURES

| Year | Author | Lecture Title |
|-------------|------------------|--|
| 1967 | J. Branger | The ICAF, Its Foundation, Growth and Today's Philosophy |
| 1969 | J. Schijve | Cumulative Damage Problems in Aircraft Structures and Materials |
| 1971 | E. L. Ripley | The Philosophy of Structural Testing a Supersonic Transport Aircraft with Particular Reference to the Influence of the Thermal Cycle |
| 1973 | E. Gassner | Fatigue Life of Structural Components Under Random Loading |
| 1975 | S. Eggwertz | Reliability Analysis of Wing Panel Considering Test Results from Initiation of First and Subsequent Fatigue Cracks |
| 1977 | H. F. Hardrath | Advanced Composites — The Structures of the Future |
| 1979 | A. J. Troughton | 33 Years of Aircraft Fatigue |
| 1981 | O. Buxbaum | Landing Gear Loads of Civil Transport Airplanes |
| 1983 | J. Y. Mann | Aircraft Fatigue — With Particular Emphasis on Australian Operations and Research |
| 1985 | L. Jarfall | Fatigue and Damage Tolerance Analysis in the Aircraft Design Process |
| 1987 | T. Swift | Damage Tolerance in Pressurized Fuselage |
| 1989 | J. B. deJonge | Assessment of Service Load Experience |
| 1991 | R. M. Bader | Structural Integrity Challenges |
| 1993 | U. G. Goranson | Damage Tolerance — Facts and Fiction |
| 1995 | W. Schutz | Corrosion Fatigue - The Forgotten Factor is Assessing Durability |
| 1997 | J. W. Lincoln | Aging Aircraft - USAF Experience and Actions |
| 1999 | J. C. Newman | Advances in Fatigue and Fracture Mechanics Analyses for Aircraft Structures |
| 2001 | A. Blom | Fatigue Science and Engineering - Achievements and Challenges |
| 2003 | L. B. Vogelesang | Fibre Metal Laminates - The Development of a New Family of Hybrid Materials |
| 2005 | H-J. Schmidt | Damage Tolerance Technology for Current and Future Aircraft Structure |
| 2007 | J. P. Gallagher | A Review of Philosophies, Processes, Methods and Approaches that Protect In-Service Aircraft from the Scourge of Fatigue Failures |

ASIP Lincoln Award



Established in 1996 by the aircraft structural integrity community to recognize a distinguished career expert who has made significant contributions toward advancements in flight vehicle structural integrity and safety. It is named in honor of the late Dr. John W. (Jack) Lincoln and is presented annually during the USAF Aircraft Structural Integrity Program (ASIP) Conference.

Details

The Medallion and Certificate are presented annually at the USAF ASIP Conference. The Plaque lists the names of Past and Present Winners and is displayed at the ASIP Conference and at WPAFB between Conferences.

Qualifications

Individual Who Has Dedicated Career to Aircraft Structural Integrity
Significant Contributions Towards Advancements in Structural Integrity
Research and Development
Engineering
Applications
Brought Distinction to Self and Field of Aircraft Structural Integrity
Internationally Recognized Expert

Previous Recipients

| | | | |
|------|----------------------------|------|---------------------|
| 1996 | Dr. John W. Lincoln | 2002 | Mr. Royce Forman |
| 1997 | Mr. Charles F. Tiffany | 2003 | Mr. Ward Rummel |
| 1998 | Mr. Thomas Swift | 2004 | Mr. Robert P. Bell |
| 1999 | Prof. Jaap Schijve | 2005 | Mr. Charles R. Saff |
| 2000 | Prof. Alten Grandt, Jr. | 2006 | Dr. Ulf G. Goranson |
| 2001 | Prof. James E. Newman, Jr. | | |

BIBLIOGRAPHY

1. Williams, J. K. "The Airworthiness Approach to Structural Fatigue." *Proceedings of the 4th Symposium of the International Committee on Aeronautical Fatigue (ICAF)*. Munich, Germany, June 16-18, 1965.
2. Smith, A. W., and Goranson, U. G. "Spectrum Loading in Relation to Aircraft Design." 8th Symposium of the International Committee on Aeronautical Fatigue (ICAF). Lausanne, Switzerland, June 1975.
3. Broek, D. "Damage Tolerance in Practice." AGARD Lecture Series No. 97 on Fatigue Mechanics in Practice. Delft, the Netherlands, October 1978.
4. Craig, L. E., and Goranson, U. G. "Airworthiness Assessment of Boeing Jet Transport Structures." 10th Symposium of the International Committee on Aeronautical Fatigue (ICAF). Brussels, Belgium, May 1979.
5. Goranson, U. G., and Hall, J. "Airworthiness of Long-Life Jet Transport Structures." Royal Aeronautical Society Spring Convention on Long-Life Aircraft Structures. London, England, May 1980.
6. Goranson, U. G., et al. "Long Life Damage Tolerant Jet Transport Structures." *ASTM Special Technical Publication 71*. American Society for Testing and Materials Fatigue and Fracture Resistant Structures. Bal Harbour, Florida, November 1980.
7. Hall, J., and Goranson, U. G. "Principles of Achieving Damage Tolerance with Flexible Maintenance Programs for New and Aging Aircraft." 13th Congress of the International Council of the Aeronautical Sciences/AIAA Aircraft Systems Technology Conference. Seattle, Washington, August 1982.
8. Rudd, J. L. "Probabilistic Fracture Mechanics Analysis Methods for Structural Durability." 55th Meeting of the AGARD Structures and Materials Panel (AGARD Proceedings No. 328). Toronto, Canada, September 19-24, 1982.
9. Goranson, U. G., and Rogers, J. T. "Elements of Damage Tolerance." 12th Symposium of the International Committee on Aeronautical Fatigue (ICAF). Toulouse, France, May 1983.
10. Gunther, C. K., and Goranson, U. G. "Spectrum Loading Effects on Crack Growth in Major Components of Commercial Transport Aircraft." International Conference on Application of Fracture Mechanics to Materials and Structures. Freiburg, Germany, June 20-24, 1983.
11. Goranson, U. G., and Hall, J. "Structural Damage Tolerance of Commercial Jet Transports." *The Boeing Airliner*. January, April and July 1984.
12. Chochola, J. J., and Spencer, M. M. "Boeing 757/767 Durability Programs." 14th Congress of the International Council of the Aeronautical Sciences (ICAS). Toulouse, France, September 1984.
13. Abelkis, P. R., Harmon, M. B., and Warren, D. S. "Continuing Structural Integrity Program for Transport Aircraft." 13th Symposium of the International Committee on Fatigue (ICAF). Pisa, Italy, May 22-24, 1985.
14. Galda, K. H. "Maintenance System by Means of Damage Tolerance Principle." 13th Symposium of the International Committee on Fatigue (ICAF). Pisa, Italy, May 22-24, 1985.
15. Goranson, U. G., Gunther, C. K., and Hardrath, W. T. "Residual Strength Characterization of JetTransport Structures." 13th Symposium of the International Committee on Aeronautical Fatigue (ICAF). Pisa, Italy, May 22-24, 1985.
16. Jongebreur, A. A., Louwaard, E. P., and Van der Velden, R. V. "Damage Tolerance Test Program of the Fokker 100." 13th Symposium of the International Committee on Fatigue (ICAF). Pisa, Italy, May 22-24, 1985.
17. Lincoln, J. W. "Damage Tolerance — USAF Experience." 13th Symposium of the International Committee on Fatigue (ICAF). Pisa, Italy, May 22-24, 1985.

18. Schijve, J. "The Significance of Flight Simulation Fatigue Tests." 13th Symposium of the International Committee on Fatigue (ICAF). Pisa, Italy, May 22-24, 1985.
19. Swift, T. "The Influence of Slow Growth and Net Section Yielding on the Residual Strength of Stiffened Structure." 13th Symposium of the International Committee on Fatigue (ICAF). Pisa, Italy, May 22-24, 1985.
20. Goranson, U. G. "Jet Transport Structures Evolution." *The Boeing Airliner*. January-March 1986.
21. Fowler, K. R., and Watanabe, R. T. "Development of Jet Transport Airframe Test Spectra." Symposium on Development of Fatigue Loading Systems, sponsored by ASTM and SAE. Cincinnati, Ohio, April 1987.
22. Miller, M., Luthra, V. K., and Goranson, U. G. "Fatigue Crack Growth Characterization of Jet Transport Structures." 14th Symposium of the International Committee on Aeronautical Fatigue (ICAF). Ottawa, Canada, June 8-12, 1987.
23. Swift, T. "Damage Tolerance in Pressurized Fuselages." 11th Plantema Memorial Lecture, 14th Symposium of the International Committee on Aeronautical Fatigue (ICAF). Ottawa, Canada, June 8-12, 1987.
24. Swift, T. "FAA Damage Tolerance Requirements — Clarification and Review." Specialist Conference on ARALL Laminates. Delft Technical University, Delft, the Netherlands, October 26, 1988.
25. Goranson, U. G., and Miller, M. "Aging Jet Transport Structural Evaluation Programs." 15th Symposium of the International Committee on Aeronautical Fatigue (ICAF). Jerusalem, Israel, June 21-23, 1989.
26. Whittaker, I. C., Miller, M., and Goranson, U. G. "Durability and Damage Tolerance Evaluations of Jet Transport Structures." 5th International Conference on Structural Safety and Reliability (ICOSSAR). San Francisco, California, August 1989.
27. Swift, T. "Damage Tolerance Capability." FAA Airframe AATF Subcommittee on Fatigue Testing and/ or Teardown Issues, Air Transport Association of America. Washington, D.C., November 1990.
28. Harradine, P. J., and Miller, M. "Safety of Aging Aircraft — Boeing Programs for the 1990s." 32nd AIAA Structures, Structural Dynamics and Materials Conference. Baltimore, Maryland, April 1991.
29. Goranson, U. G. "The Aging Fleet Challenge." International Aerospace Congress 1991. Melbourne, Australia, May 1991.
30. Bader, R. M. "Structural Integrity Challenges." 16th Symposium of the International Committee on Fatigue (ICAF). Tokyo, Japan, May 20-24, 1991.
31. Emmerson, A. J. "New Lamps for Old Safety Regulation through Structural Airworthiness Standards." 16th Symposium of the International Committee on Aeronautical Fatigue (ICAF). Tokyo, Japan, May 20-24, 1991.
32. Gaillardon, J. M., Schmidt, H. J., and Brandecker, B. "Aging Airplane Repair Assessment Program for Airbus A300." 16th Symposium of the International Committee on Aeronautical Fatigue (ICAF). Tokyo, Japan, May 20-24, 1991.
33. Hoggard, A. W. "Maintaining the Safety of an Aging Fleet of Aircraft." 16th Symposium of the International Committee on Aeronautical Fatigue (ICAF). Tokyo, Japan, May 20-24, 1991.
34. Lincoln, J. W. "Damage Tolerance for Commuter Aircraft." 16th Symposium of the International Committee on Aeronautical Fatigue (ICAF). Tokyo, Japan, May 20-24, 1991.
35. Tong, P., Sampath, S. G., and Broek, D. "Aging Aircraft, Detection of Multiple Site Damage and the Risk of Failure." 16th Symposium of the International Committee on Aeronautical Fatigue (ICAF). Tokyo, Japan, May 20-24, 1991.
36. Whittaker, I. C., Stilwell, P. B., and Sizemore, D. R. "Reel Fatigue Cracking Threshold Prediction." 16th Symposium of the International Committee on Aeronautical Fatigue (ICAF). Tokyo, Japan, May 20-24, 1991.

37. Bristow, J. W. "Structural Repairs — The Airworthiness Patch." International Conference on Aircraft Damage Assessment and Repair. Melbourne, Australia, August 26-28, 1991.
38. Sampath, S. G., and Broek, D. "The Prospect of Detecting and Dealing with Widespread Fatigue Damage: Threshold for Inspecting MSD Susceptible Lap Splices." International Conference on Aircraft Damage Assessment and Repair. Melbourne, Australia, August 26-28, 1991.
39. Maclin, J. R. "Performance of Fuselage Pressure Structure." 3rd International Conference on Aging Aircraft and Structural Airworthiness. Washington, D.C., November 19-21, 1991.
40. Gaillardon, J. M., Schmidt, H. J., and Brandecker, B. "Aging Airplane Repair Assessment Program for Airbus A300." 3rd International Conference on Aging Aircraft and Structural Airworthiness. Washington, D.C., November 19-21, 1991.
41. Miller, M., Kaelber, K. N., and Worden, R. E. "Finite Element Analysis of Pressure Vessel Panels." International Workshop on Structural Integrity of Aging Airplanes. Atlanta, Georgia, March 1992.
42. Hoggard, A. W. "Aging Aircraft — The Manufacturer Point of View." Aging Aircraft and Air Safety Operation Seminar 1992. Jakarta, Indonesia, March 5, 1992.
43. Lincoln, J. W. "Risk Assessment — USAF Experience." *Proceedings of the International Workshop on Structural Integrity of Aging Airplanes*. Atlanta, Georgia, March 31-April 2, 1992.
44. Schijve, J. "Multiple Site Fatigue Damage of Riveted Joints." *Proceedings of the International Workshop on Structural Integrity of Aging Airplanes*. Atlanta, Georgia, March 31-April 2, 1992.
45. Schmidt, H. J., and Brandecker, B. "Results of the AAWG Industry Committee on Widespread Fatigue Damage." *Proceedings of the International Workshop on Structural Integrity of Aging Airplanes*. Atlanta, Georgia, March 31-April 2, 1992.
46. Swift, T. "Unarrested Fast Fracture." *Proceedings of the International Workshop on Structural Integrity of Aging Airplanes*. Atlanta, Georgia, March 31-April 2, 1992.
47. Tong, P., Greif, R., and Chen, L. "Residual Strength of Aircraft Panels with Multiple Site Damage." *Proceedings of the International Workshop on Structural Integrity of Aging Airplanes*. Atlanta, Georgia, March 31-April 2, 1992.
48. Schmidt, H. J., and Brandecker, B. "Airbus A300 Methodology for Determination of Inspection Requirements for Skin Repairs on Pressurized Fuselage." FAA Repair Workshop. Seattle, Washington, May 14, 1992.
49. Schijve, J. "Fatigue Predictions and Scatter." Faculty of Aerospace Engineering. Report LR696. Delft Technical University, Delft, the Netherlands, August 1992.
50. Broek, D. "Fatigue and Damage Tolerance." *Proceedings of Fatigue Specialist Conference*. Delft Technical University, Delft, the Netherlands, October 14-15, 1992.
51. Goranson, U. G. "Elements of Structural Integrity Assurance." *Proceedings of Fatigue Specialist Conference*. Delft Technical University, Delft, the Netherlands, October 14-15, 1992.
52. Swift, T. "Damage Tolerance Capability." *Proceedings of Fatigue Specialist Conference*. Delft Technical University, Delft, the Netherlands, October 14-15, 1992.
53. Broek, D. "The Civil Damage Tolerance Requirements in Theory and Practice." Fractu REsearch Inc., Galena, Ohio (private communication, 1990).
54. Goranson, U.G. "Structural Airworthiness Initiatives." International Conference on Aviation Safety and Security in the 21st Century. The White House Commission. George Washington University, Washington, D.C., January 14th, 1997.

ACKNOWLEDGEMENTS

Many of my colleagues in the aerospace industry have contributed their thoughts and professional skills to the content of this lecture. The author is greatly indebted to several Boeing and airline structural specialists for their technical contributions and frequent kind reminders of facts and fiction in the pursuit of continued structural airworthiness of commercial jet transports.

Special thanks is truly deserved by my personal assistant, Mrs. Linda J. Begley, for her continuous quest for excellence in the manuscript preparation and editing. The contributions of Mr. Chris J. Mazur and Mr. Keith E. Wilkins with numerous analyses, compilation of illustrations and manuscript reviews made the completion of the lecture a reality. Coordination of graphics support by Mr. Wayne J. Brewer is also truly appreciated. The team deserves full credit for the lecture content acceptance but none of the blame for any shortcomings.

Special appreciation goes to my wife, Inger, last in mention but first in anything else that matters. She has patiently endured my long hours in the office to finish this task amidst other equally pressing business priorities.

The author is truly indebted to Boeing Creative Services of Boeing Commercial Airplane Company. Their skilled team made the Lincoln Award Plenary Lecture possible by converting old graphic originals to PowerPoint.

The continued support by my friend and previous co-worker Mr. Wayne Brewer made this project a reality with high quality results.